

Models:

A5CKY28ER
A5CKY40ER
A5CKY50ER

A5CCY28CR
A5CCY38CR
A5CCY50CR
A5CCY60CR

A5CMY28ER
A5CMY40ER
A5CMY50ER
R5CMY62CR

ACSON[®]
International



INVERTER Y SINGLE SPLIT SERIES II

Table of Contents

Nomenclature	4
Indoor Unit	4
Outdoor Unit	4
Product Line-Up.....	5
Application Information	7
Operating Range	7
Refrigerant Circuit Diagrams	8
Installation Guideline	9
Sound Data	14
Sound Pressure Level	14
NC Curve.....	17
Engineering & Physical Data	23
Outlines & Dimensions	30
Wiring Diagrams	34
Service & Maintenance	45
Troubleshooting	47
Exploded View and Part List	52

“Acson” is a registered trademark of Acson International. All rights reserved.

© 2011 Acson International. All rights reserved throughout the world.

Bulletin illustrations cover the general appearance of Acson International products at the time of publication.

We reserve the right to change design and construction specifications at any time without notice.

Nomenclature

Indoor Unit

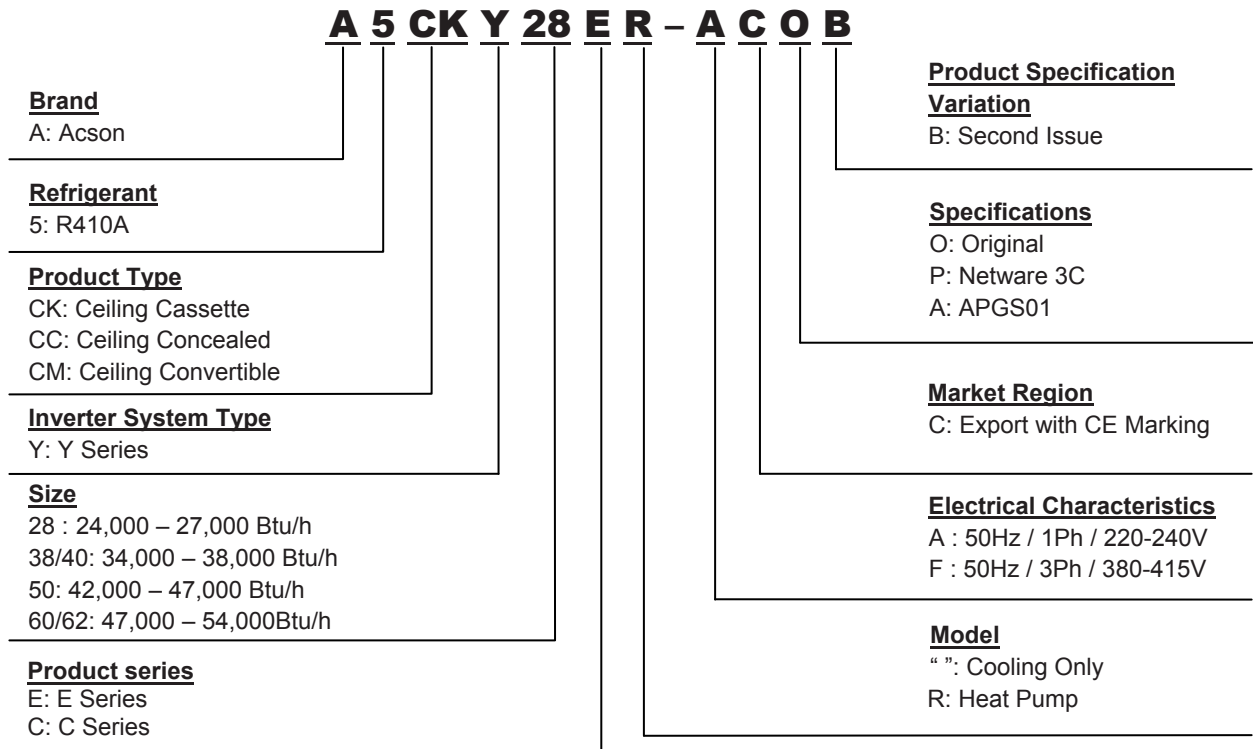

Outdoor Unit

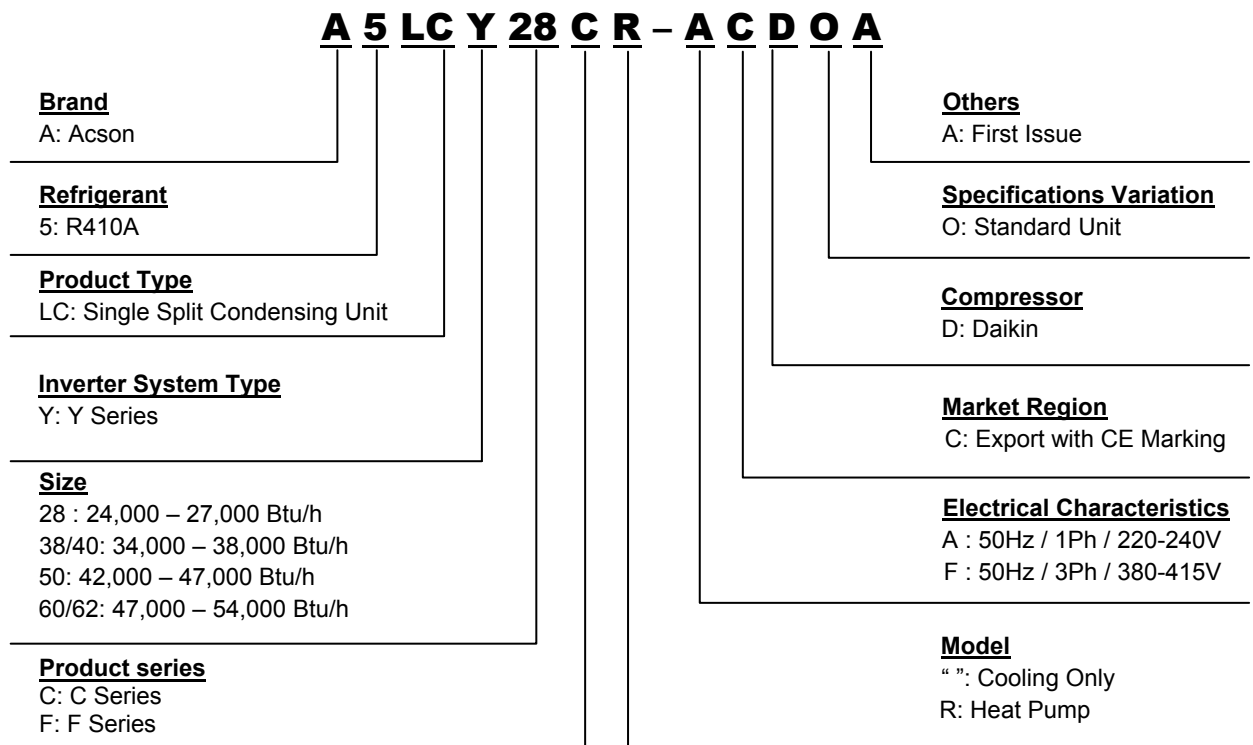

Product Line-Up

Indoor Unit A5CKY-ER

Model	Nomenclature	Classification						
		PCB	Handset	Air Purification		Marking	Others	
		C_2_01A_M	APGS01	Negative Ionizer	Saranet Filter	CE	Auto Restart	
HEATPUMP	28ER	ACOB	X				X	X
	40ER	ACOA	X				X	X
	50ER	ACOA	X				X	X
	PLCKY ER	PGS01		X		X	X	

Indoor Unit A5CCY-CR

Model	Nomenclature	Classification						
		PCB	Handset	Air Purification		Marking	Others	
		C_2_01A_M	Netware3	Negative Ionizer	Saranet Filter	CE	Auto Restart	
HEATPUMP	28CR	ACPB	X	X		X	X	X
	38CR	ACPA	X	X		X	X	X
	50CR	ACPA	X	X		X	X	X
	60CR	ACPA	X	X		X	X	X

**Indoor Unit
A5CMY-ER**

Model	Nomenclature	Classification							
		PCB		Handset		Air Purification		Others	
		C_2_01A_M	APGS01	Negative Ionizer	Saranet Filter	CE	Auto Restart	Convertible	
HEATPUMP	28ER	ACAB	X	X		X	X	X	X
	40ER	ACAA	X	X		X	X	X	X
	50ER	ACAA	X	X		X	X	X	X
	62CR	ACAA	X	X		X	X	X	

**Outdoor Unit
A5LCY**

Model	Nomenclature	Classification								
		PCB		Refrigerant Control		Compressor		Fin		Marking
		2P187323-1	1P161404-1	EXV	Cap Tube	DC Inverter Swing Compressor	DC Inverter Scroll Compressor	Bare	Blue Coated	CE
HEATPUMP	28CR	ACDOA		X	X		X		X	X
	40FR	ACDA	X		X			X	X	X
		FCDA	X		X			X	X	X
	50FR	ACDA	X		X			X	X	X
		FCDA	X		X			X	X	X
	60FR	ACDA	X		X			X	X	X
FCDA		X		X			X	X	X	

Application Information

Operating Range

Ensure the operating temperature is in allowable range.

Cooling

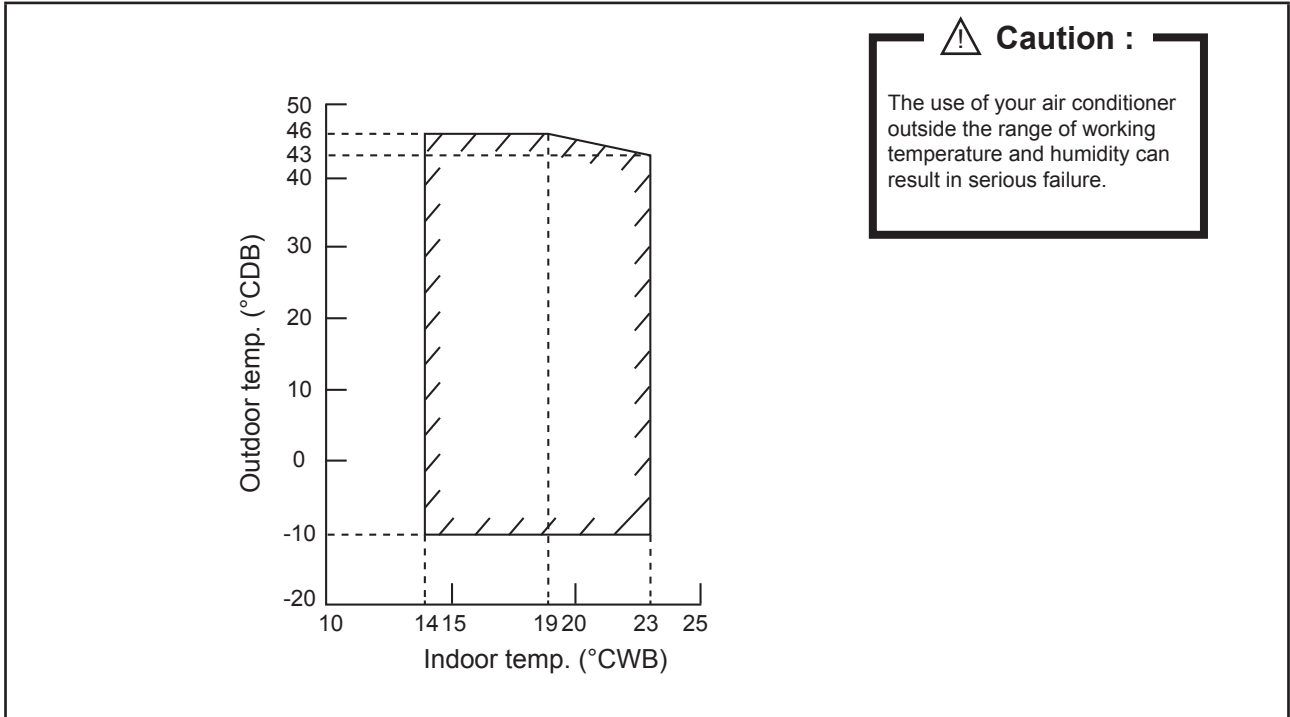

Heating

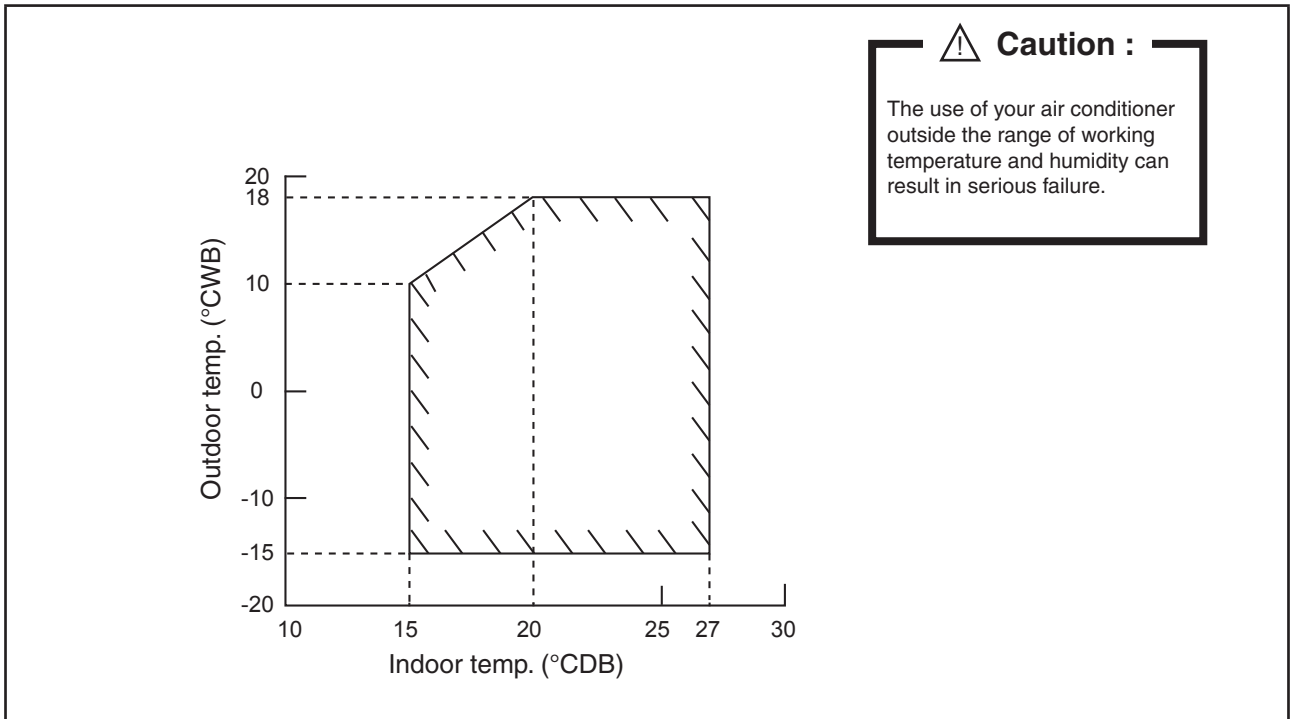

Refrigerant Circuit Diagrams

Model: A5CKY28ER / A5CMY28ER / A5CCY28CR – A5LCY28CR
A5CKY40ER / A5CMY40ER / A5CCY38CR – A5LCY40FR
A5CKY50ER / A5CMY50ER / A5CCY50CR – A5LCY50FR
R5CMY62CR / A5CCY60CR – A5LCY60FR

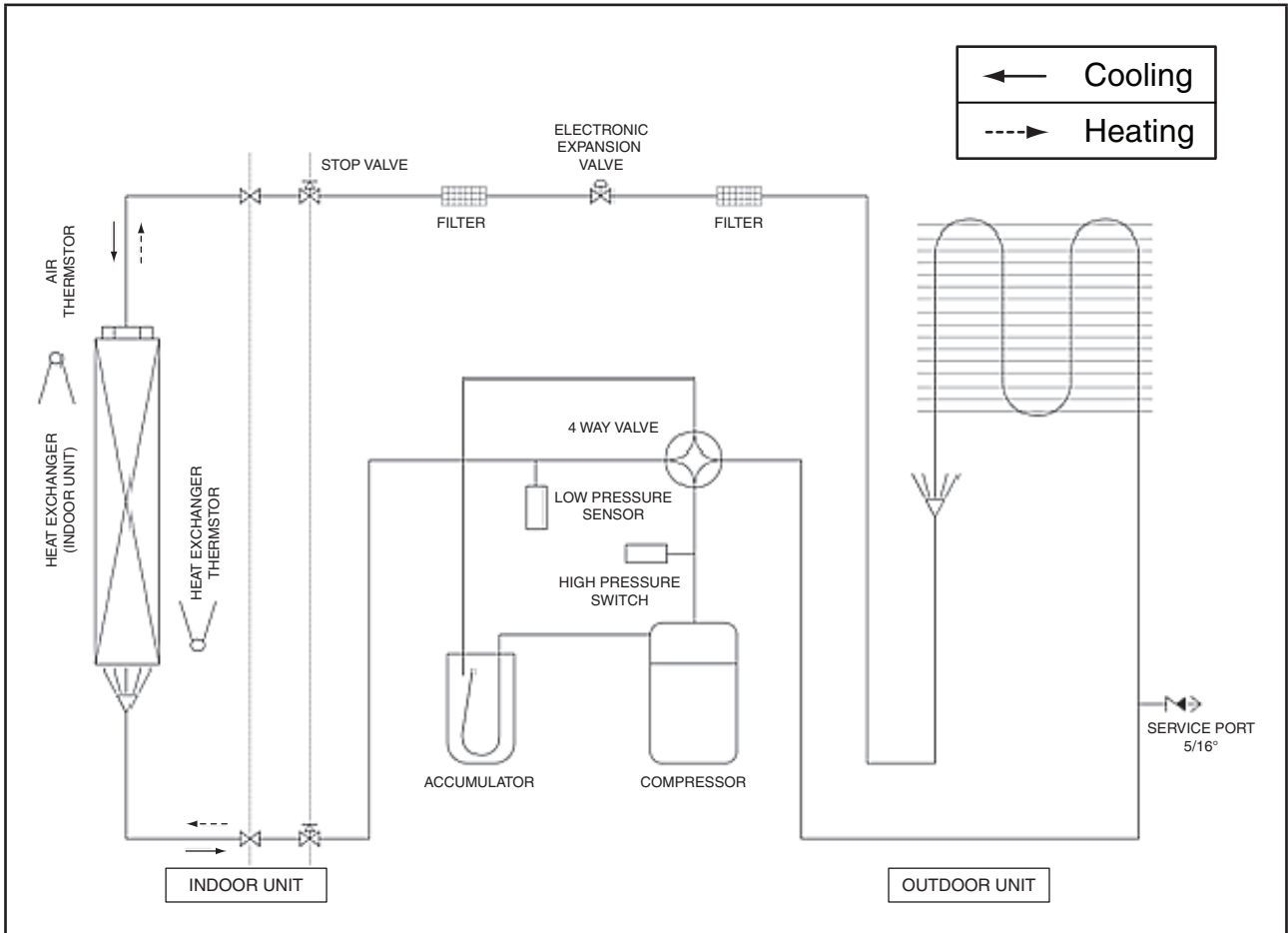

Part Number: 70034108870

Installation Guideline



Caution

Sharp edges and coil surfaces are potential injury hazard. Avoid from contact with them.

Installation diagram

A5CKY 28/40/50ER

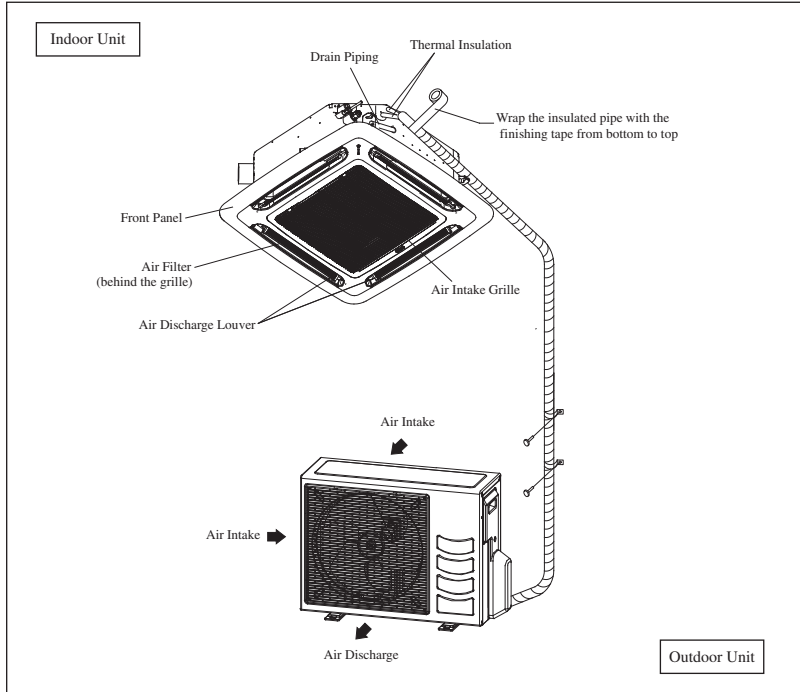

A5CMY 28ER

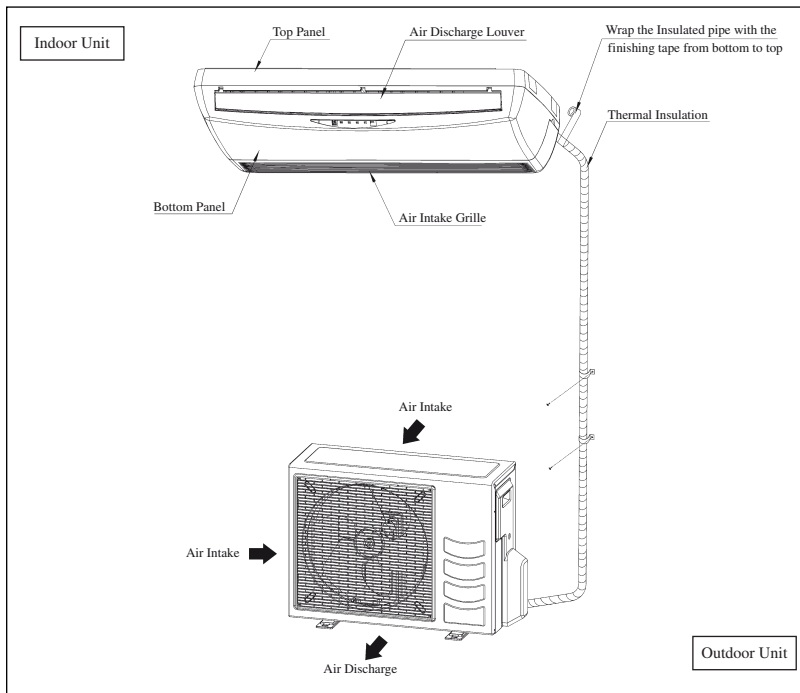

A5CMY 40/50ER

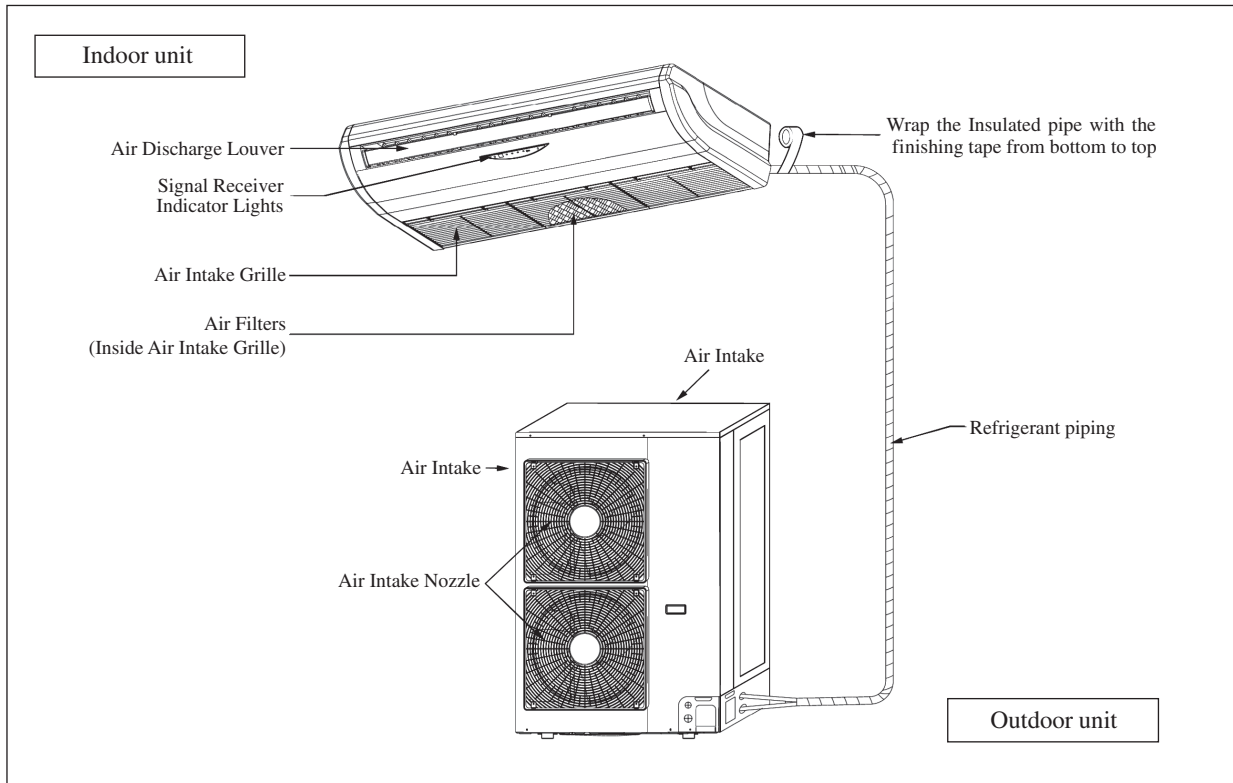

A5CMY 62CR

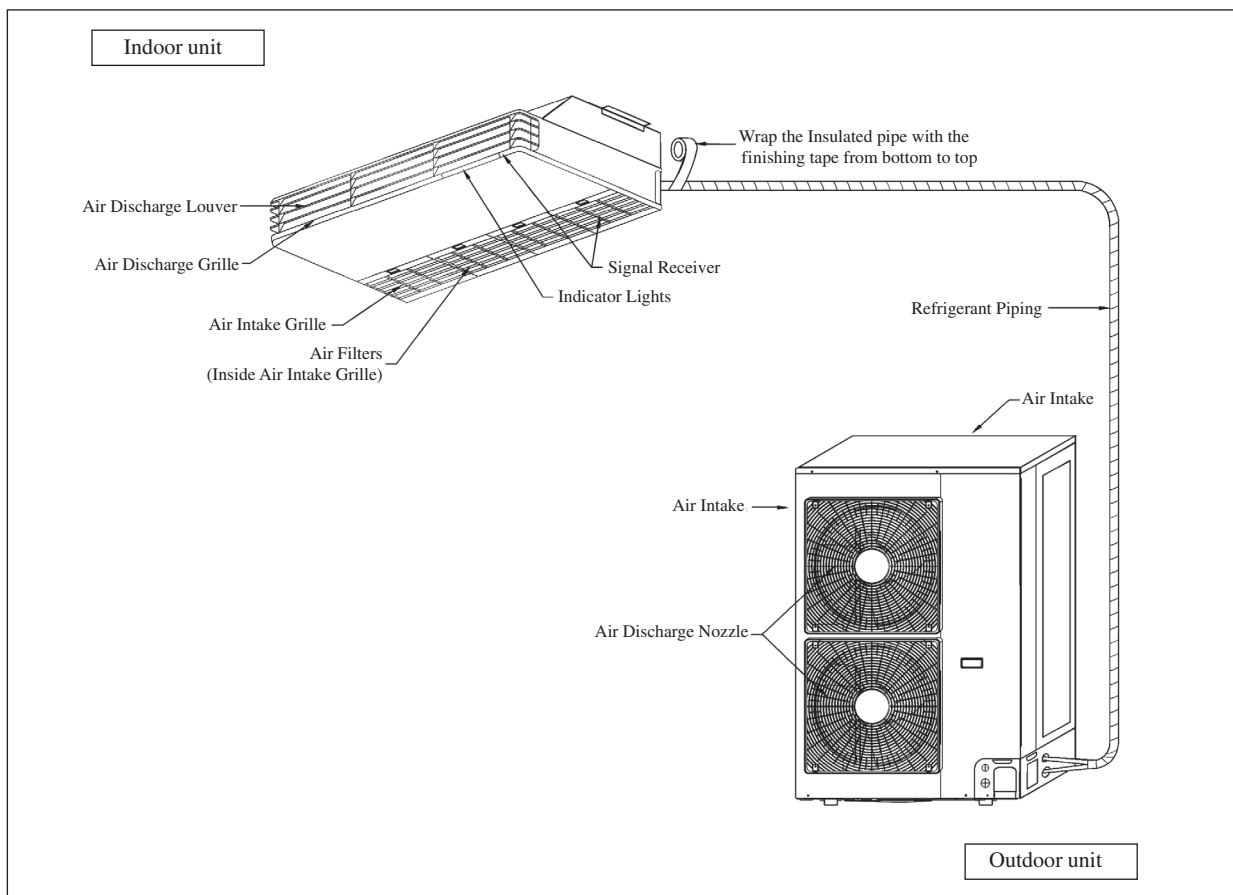

A5CCY 28/38/50/60CR

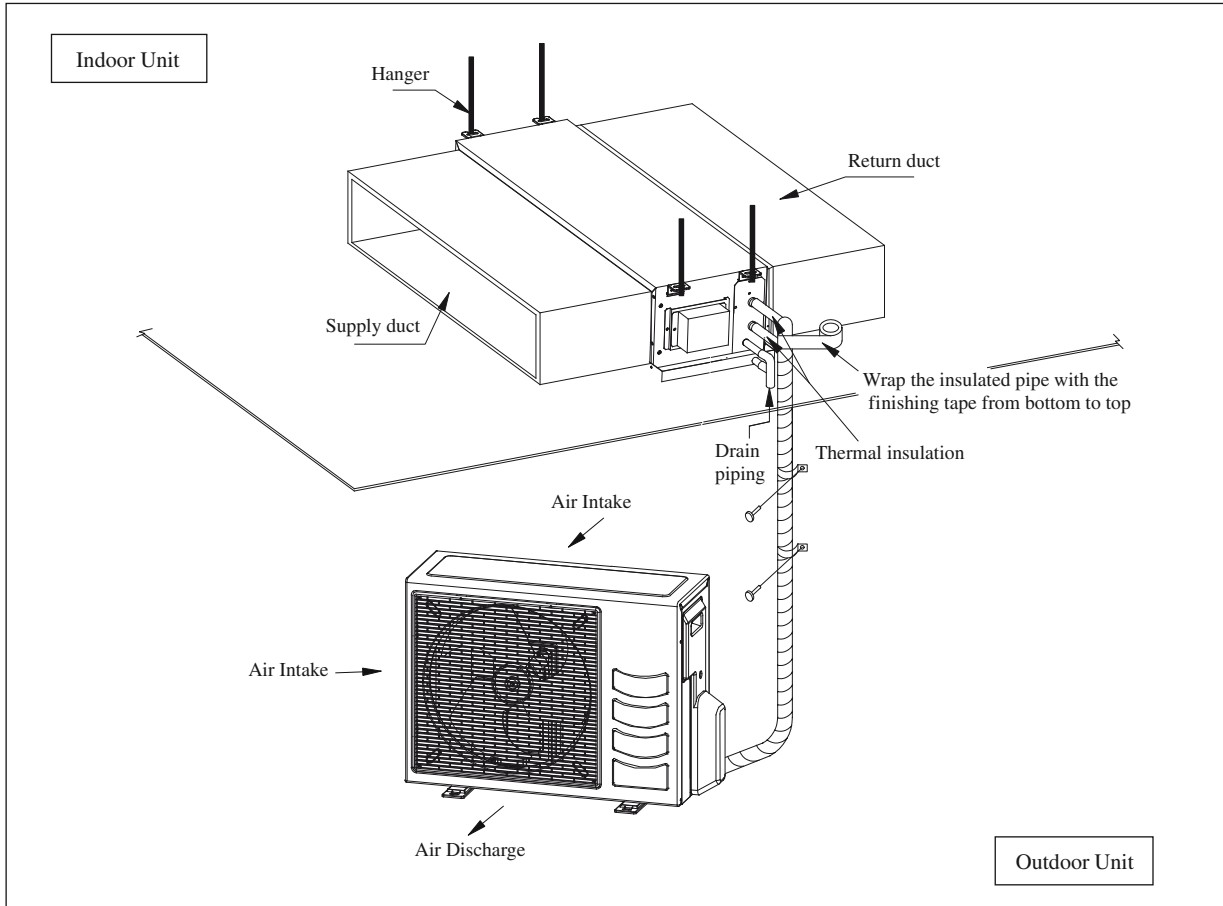

Outdoor Clearance



Caution

If the condensing unit is operated in an atmosphere containing oils (including machine oils), salt (coastal area), sulphide gas (near hot spring, oil refinery plant), such substances may lead to failure of the unit.

A5LCY 28CR

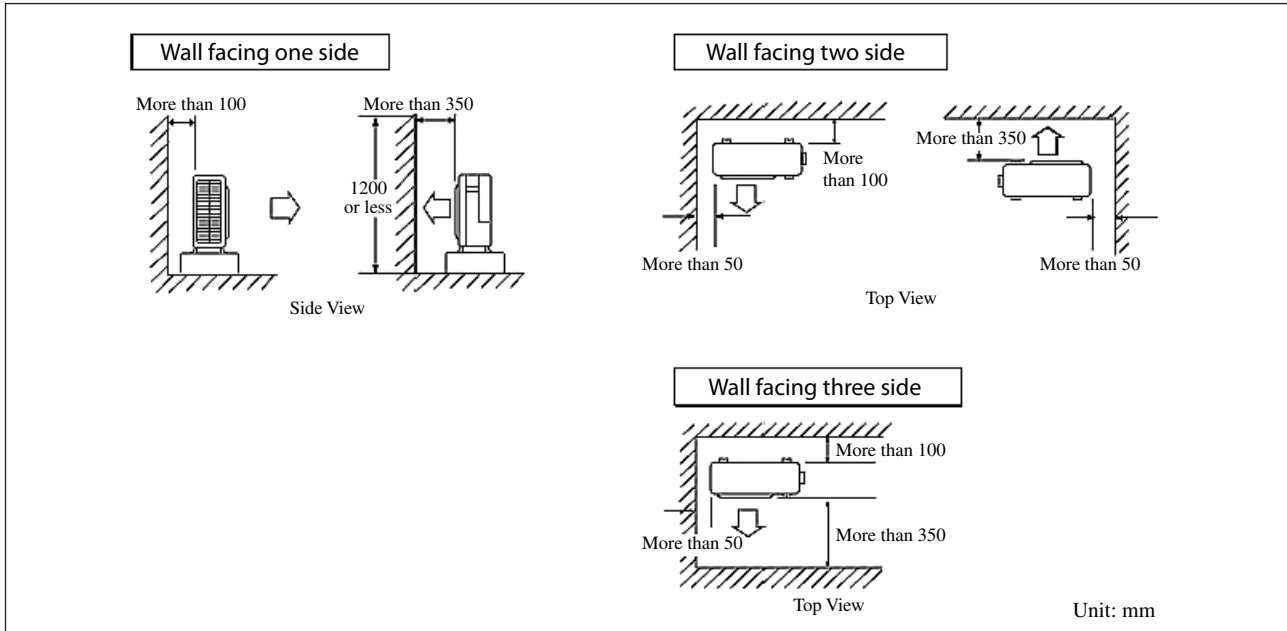

A5LCY 40/50/60FR

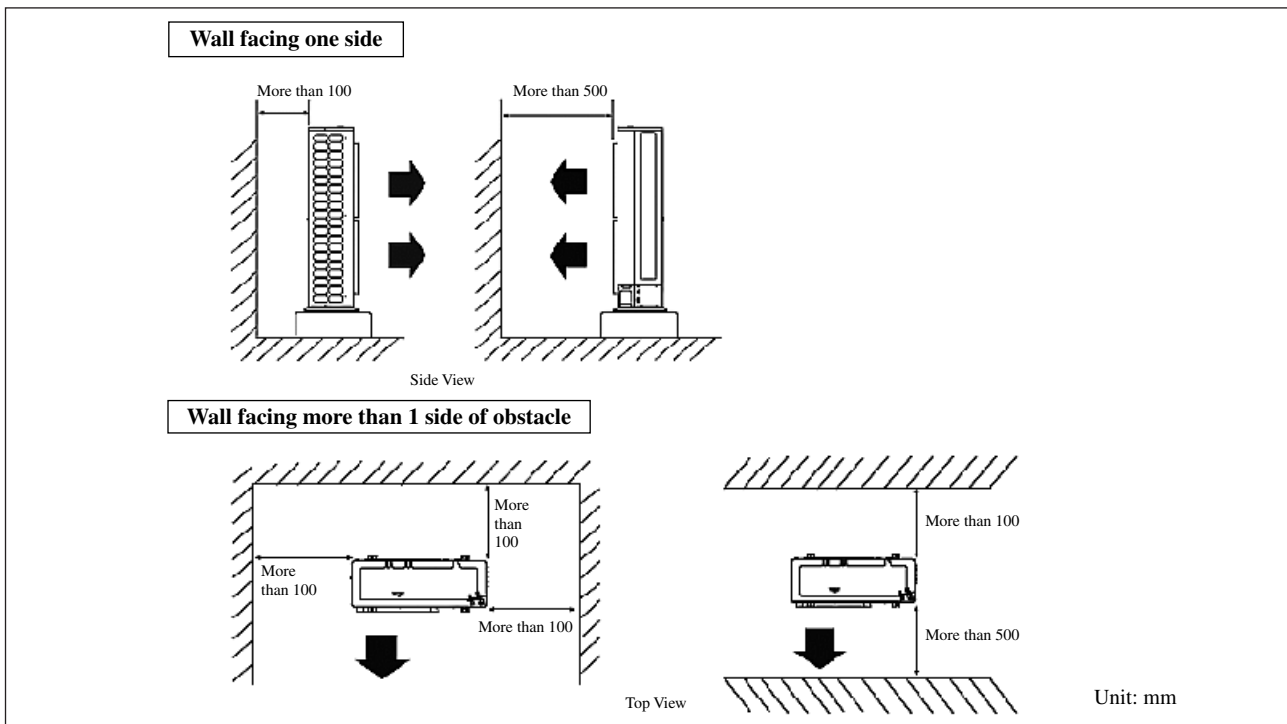

Cable Size

Model	Unit	A5CKY 28ER A5CMY 28ER A5CCY 28CR	A5CKY 40/50ER A5CMY 40/50ER A5CMY 62CR A5CCY 38/50/60CR	A5CKY 40/50ER A5CMY 40/50ER A5CMY 62CR A5CCY 38/50/60CR (3 phase)
Power supply cable size	mm ²	2.5	6	4
Number of wire		3	3	5
Interconnection cable size	mm ²	1.5	1.5	1.5
Number of wire		4	4	4
Recommended fuse	A	25	32	20

Refrigerant Piping

Model	Indoor	A5CKY 28ER A5CMY 28ER A5CCY 28CR	A5CKY 40/50ER A5CMY 40/50ER A5CMY 62CR A5CCY 38/50/60CR
	Outdoor	A5LCY 28CR	A5LCY 40/50/60FR
Max. Length, m		50	75
Min. Length, m		3	3
Max. Elevation, m		30	30
Liquid, mm / in		9.52 / 3/8"	
Suction, mm / in		15.88 / 5/8"	

Additional Charge

Indoor	A5CKY 28ER A5CMY 28ER	A5CKY 40/50ER A5CMY 40/50ER A5CMY 62CR A5CCY 38/50/60CR
Outdoor	A5LCY 28CR	A5LCY 40/50/60FR
Add Charge, g/m	50	50
For piping length above, m	7.6	30

Note: Installation and maintenance are to be performed only by qualified personnel who are familiar with local codes and regulations, and experienced with this type of equipment

Sound Data

Sound Pressure Level

Model	Speed	1/1 Octave A-Weighted Sound Pressure (dBA), ref 20µPa							Overall (dBA)	Noise Criteria
		125Hz	250Hz	500Hz	1kHz	2kHz	4kHz	8kHz		
A5CKY 28ER	High	45	43	42	35	29	22	11	41	37
	Med	40	41	39	30	24	15	7	38	34
	Low	38	38	35	26	19	9	5	35	30
	S Low	35	35	33	23	14	5	4	32	28
A5CKY 40ER	High	48	45	44	38	30	28	15	44	39
	Med	49	42	41	34	25	21	8	41	36
	Low	48	39	38	31	21	13	6	38	33
	S Low	45	35	36	26	15	5	5	35	31
A5CKY 50ER	High	50	48	46	42	33	32	20	47	41
	Med	52	45	43	38	29	27	13	44	38
	Low	53	43	42	37	27	24	10	43	37
	S Low	51	41	39	32	23	16	6	39	34

Part Number: 000152103N2828, 000153103P4040, 000153103P5050

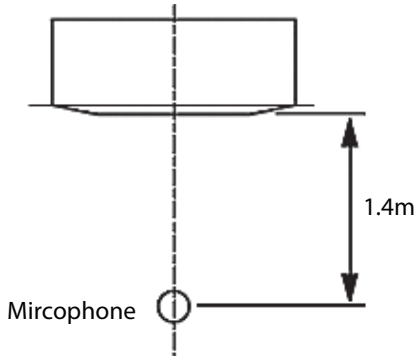
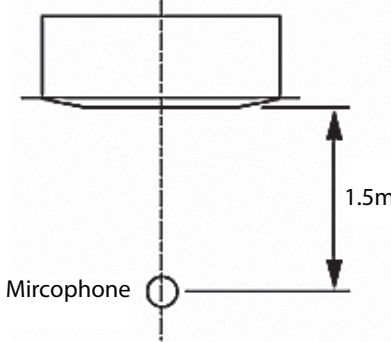
Model	Measuring Location
A5CKY 28ER	 <p>Standard: JIS C 9612</p>
A5CKY 40/50ER	 <p>Standard: JIS B 8616</p>

Model	Speed	1/1 Octave A-Weighted Sound Pressure (dBA), ref 20μPa							Overall (dBA)	Noise Criteria
		125Hz	250Hz	500Hz	1kHz	2kHz	4kHz	8kHz		
A5CMY 28ER	High	47	50	53	50	50	43	39	56	51
	Med	44	46	49	46	45	38	33	51	46
	Low	38	40	43	38	37	28	22	44	38
A5CMY 40ER	High	44	49	46	48	47	40	33	62	48
	Med	42	47	44	45	43	33	26	47	44
	Low	39	44	41	42	39	31	23	46	41
A5CMY 50ER	High	47	50	49	47	45	41	30	52	46
	Med	45	48	47	46	43	38	28	50	45
	Low	44	47	46	44	41	37	28	49	43
A5CMY 62CR	High	34	45	49	52	49	44	37	56	51
	Med	32	43	46	49	46	41	33	53	48
	Low	26	36	40	42	38	32	24	46	41

Part Number: 00153103M2828, 00153103R4040, 00153103R5050, 00153103CY6260

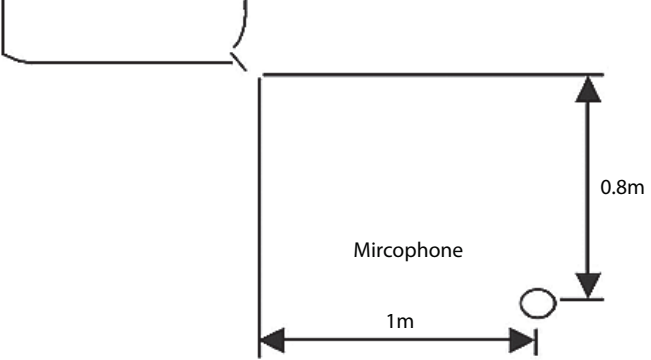
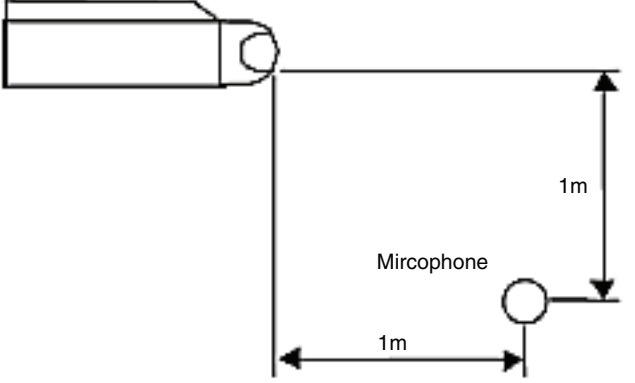
Model	Measuring Location
A5CMY 28/40/50ER	 <p>Standard: JIS C 9612</p>
A5CMY 62R	 <p>Standard: JIS B 8615</p>

Model	Speed	1/1 Octave A-Weighted Sound Pressure (dBA), ref 20µPa							Overall (dBA)	Noise Criteria
		125Hz	250Hz	500Hz	1kHz	2kHz	4kHz	8kHz		
A5CCY 28CR	S.High	48	45	42	38	34	29	26	44	37
	High	45	42	39	35	31	26	22	41	34
	Med	42	38	37	32	28	22	17	38	32
	Low	36	33	33	27	23	16	11	34	27
A5CCY 38CR	S.High	56	57	53	50	46	41	36	55	49
	High	54	51	48	46	41	36	31	51	45
	Med	51	48	46	45	37	32	26	48	44
	Low	47	45	44	41	34	28	22	45	40
A5CCY 50CR	S.High	56	50	50	49	44	38	33	53	48
	High	54	49	49	48	43	37	32	52	47
	Med	53	47	46	47	40	35	29	50	46
	Low	51	45	44	44	36	32	26	47	43
A5CCY 60CR	S.High	57	50	51	51	46	39	35	55	50
	High	55	49	49	50	44	37	33	53	49
	Med	53	46	47	47	39	34	28	50	46
	Low	51	43	44	43	35	30	24	47	42

Part Number: 000152103K2828, 000152103Q3840, 000152103Q5050, 000152103Q6060

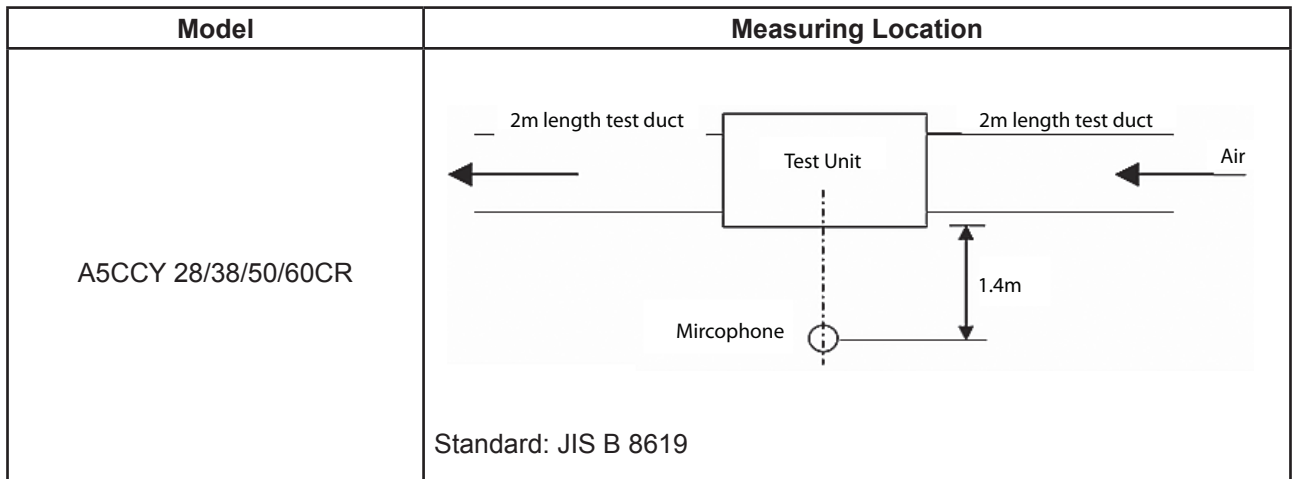

NC Curve

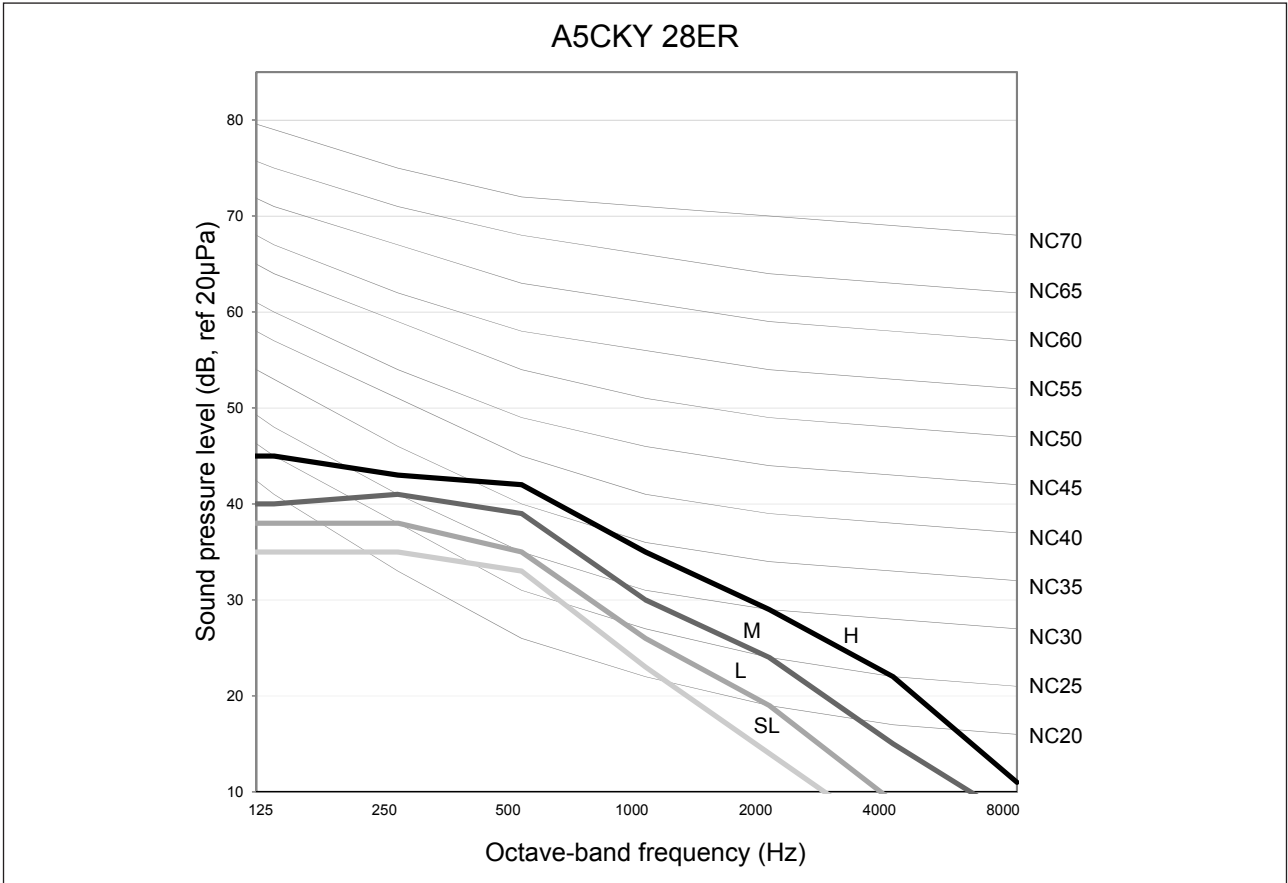

Part Number: 000352103N2828

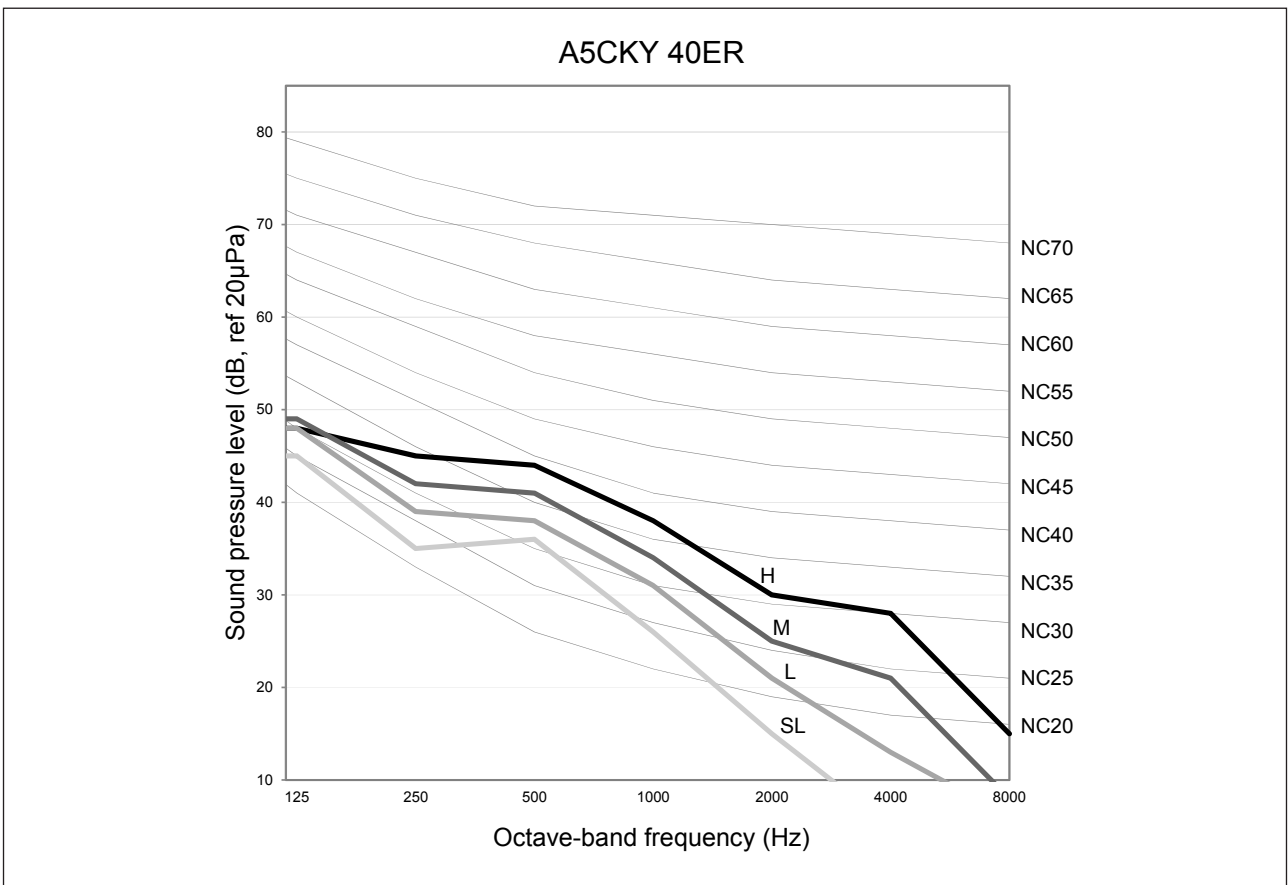

Part Number: 000352103P4040

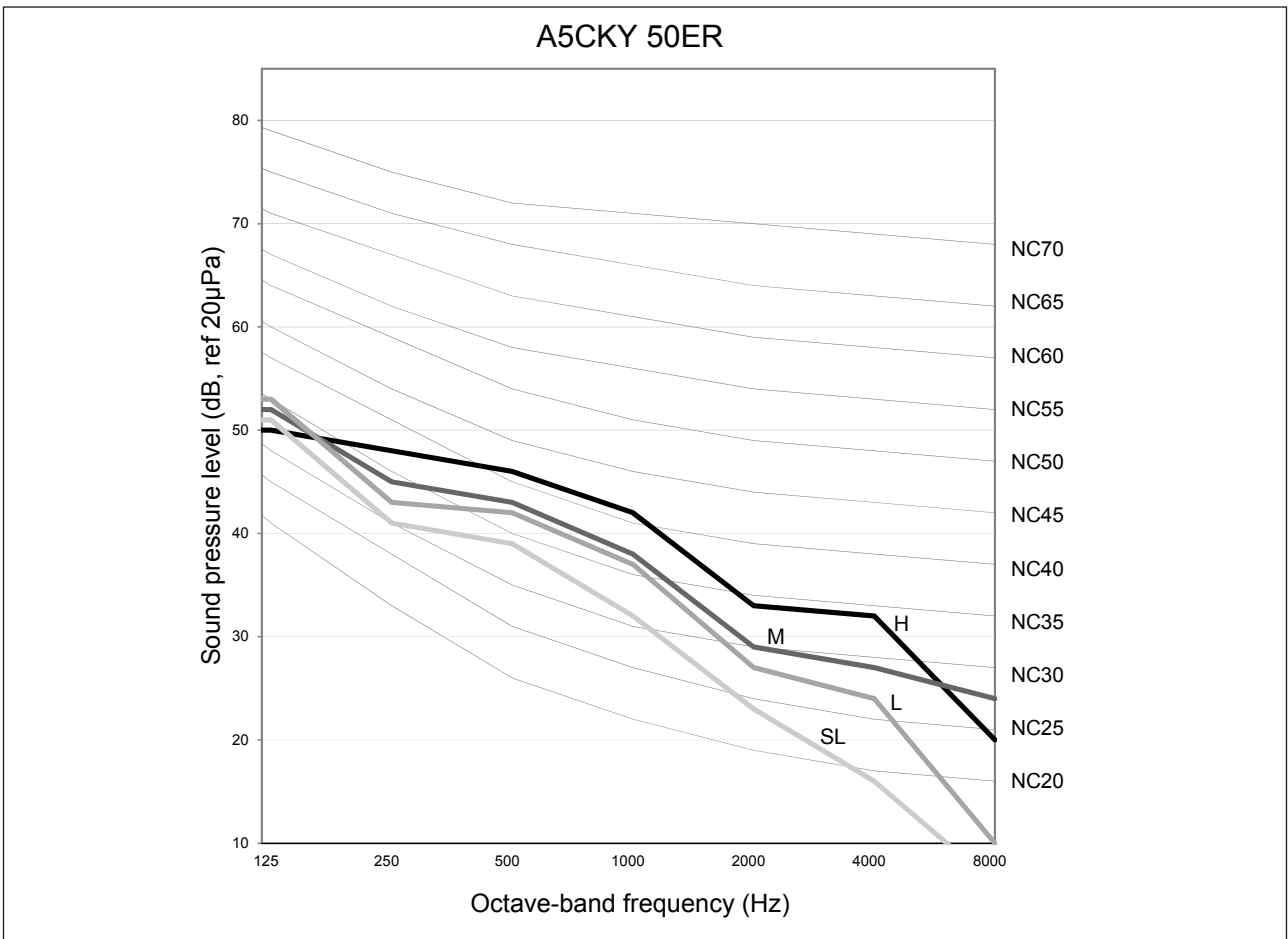

Part Number: 000352103P5050

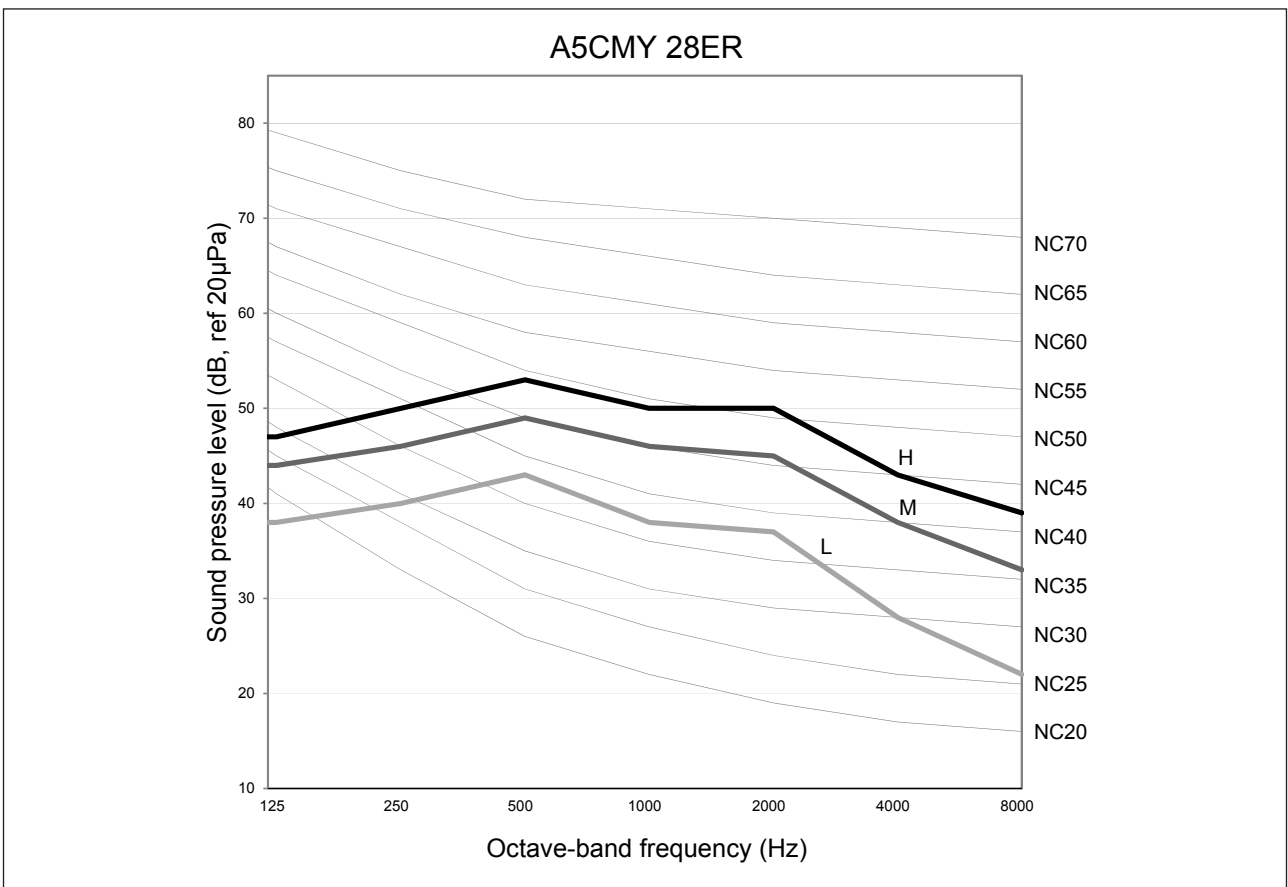

Part Number: 000352103M2828

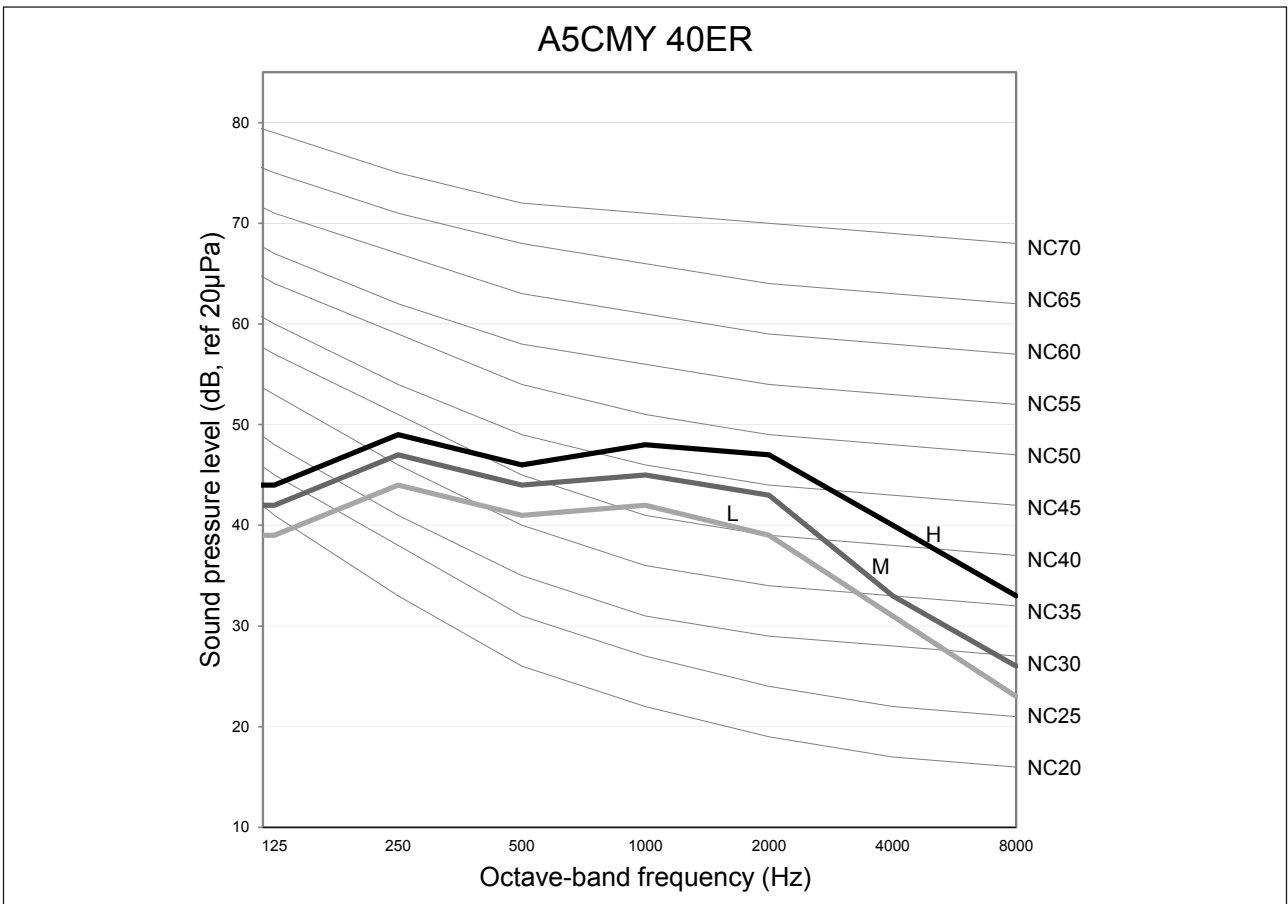

Part Number: 000352103R4040

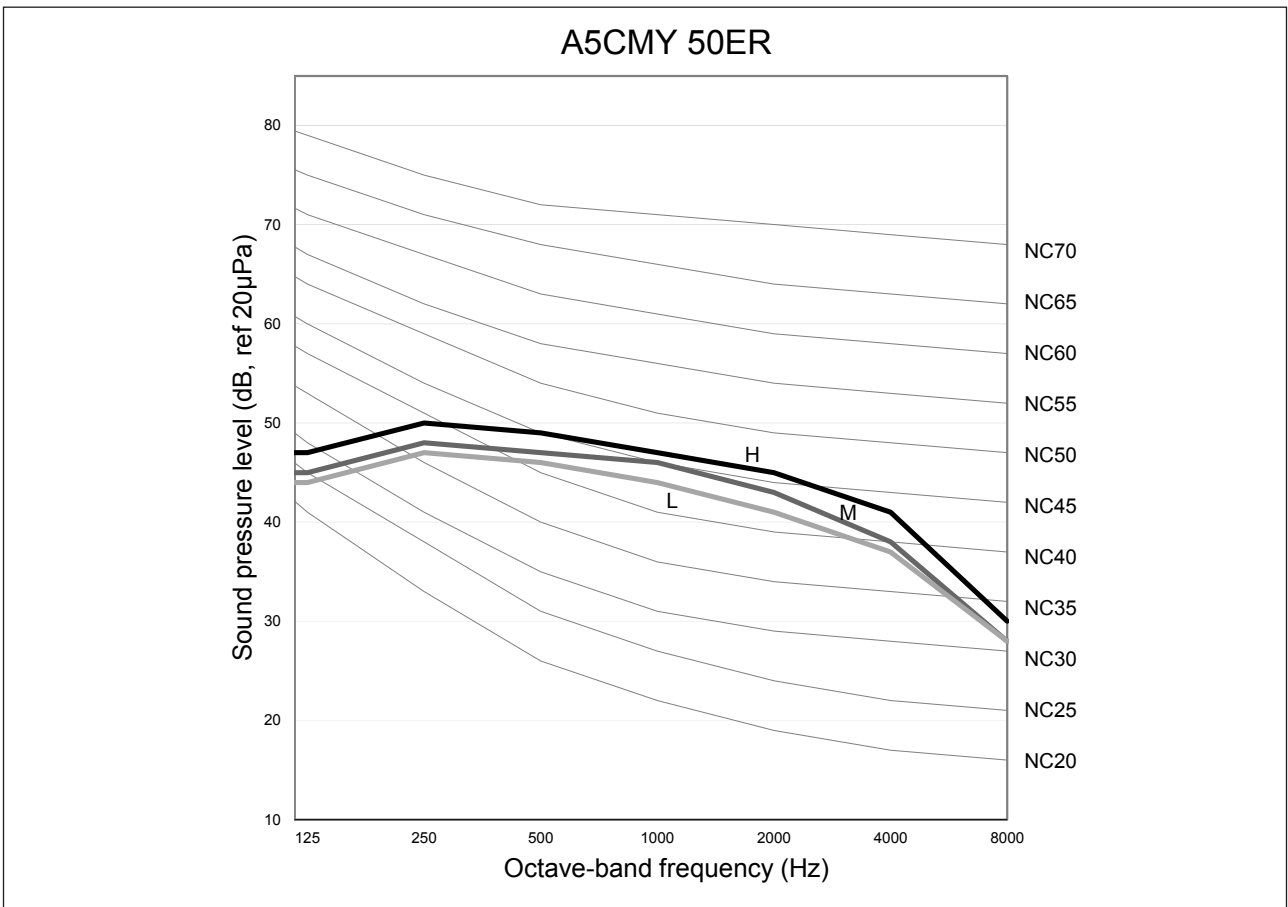

Part Number: 00035210R5050

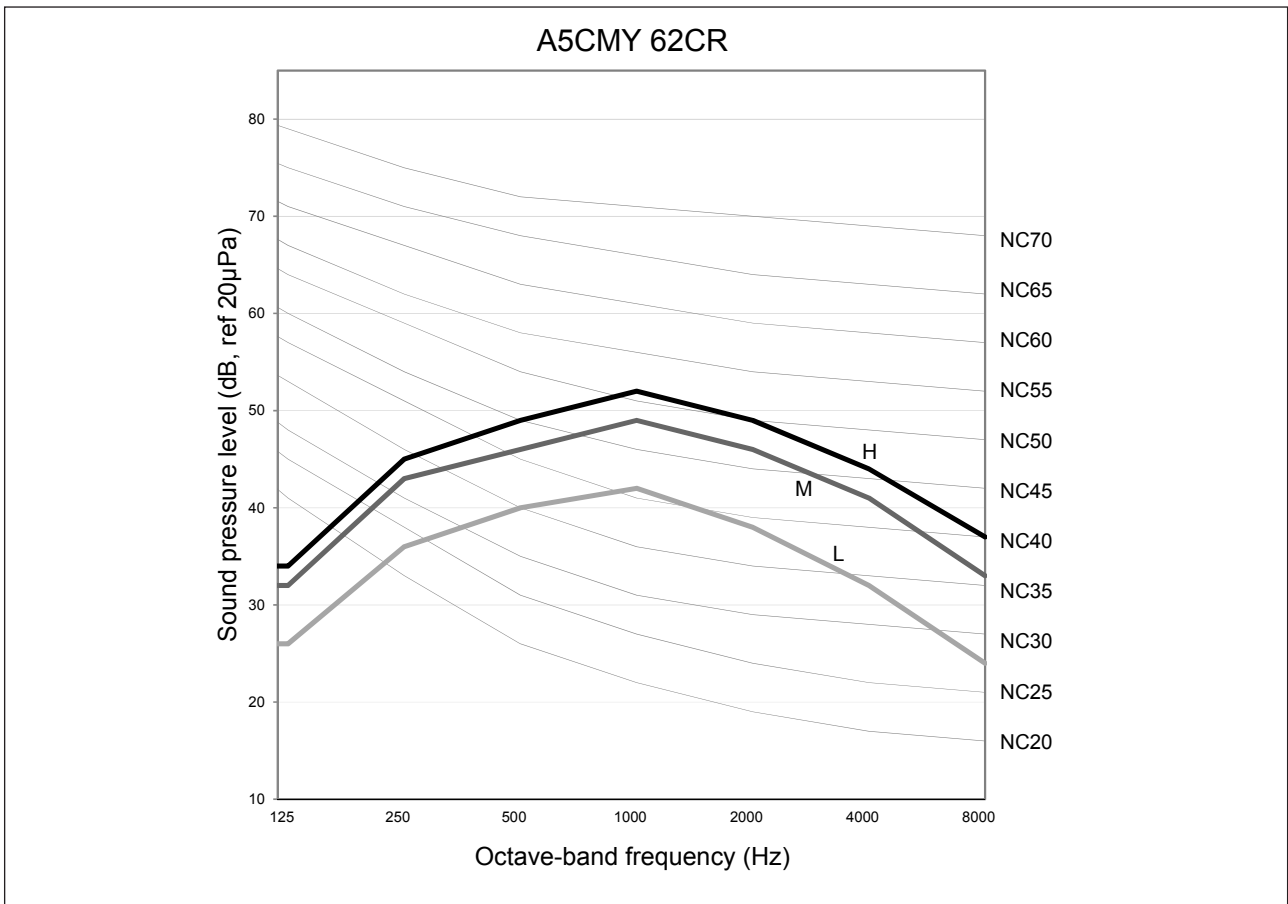

Part Number: 000352103CY6260

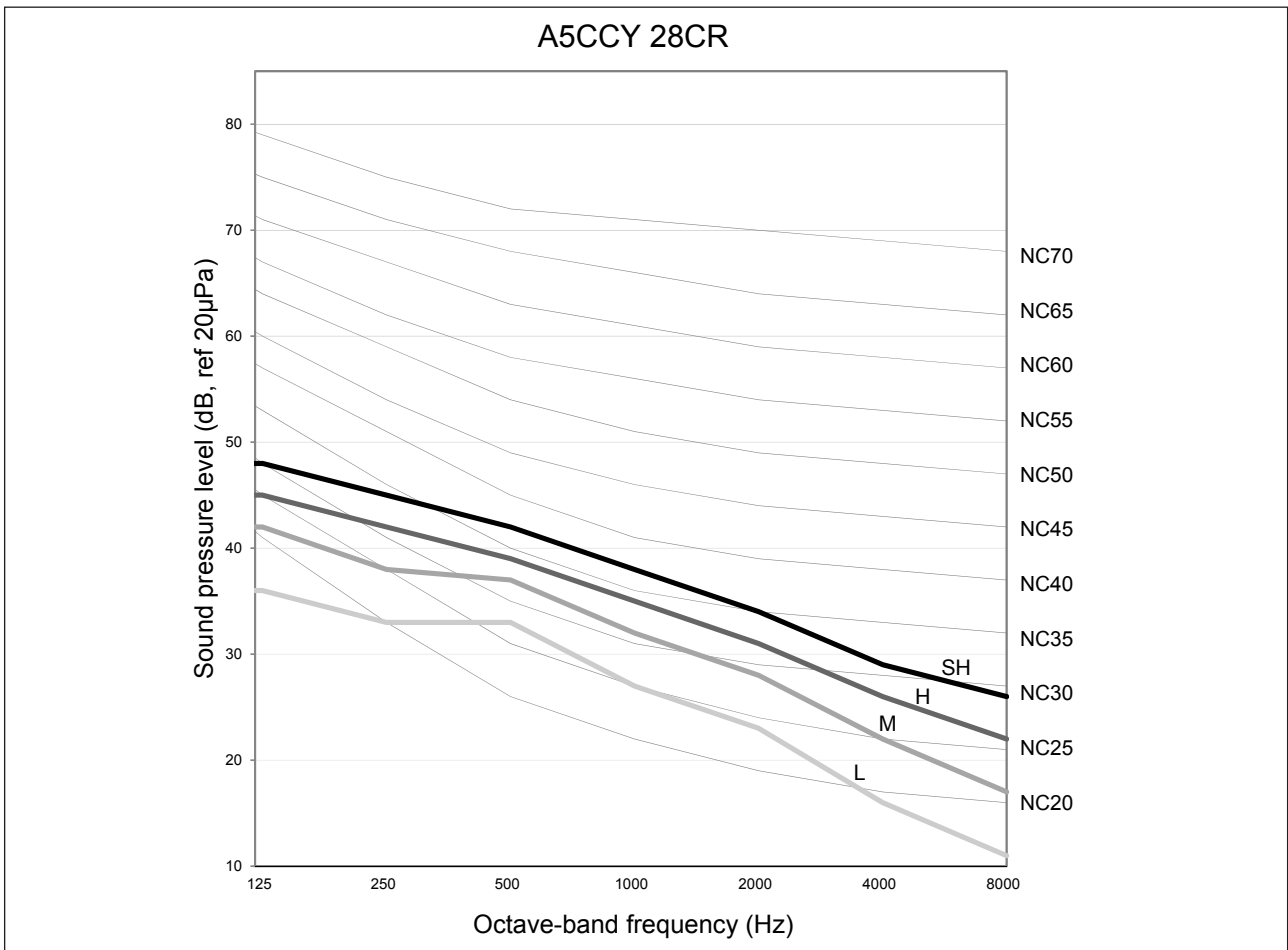

Part Number: 000352103K2828

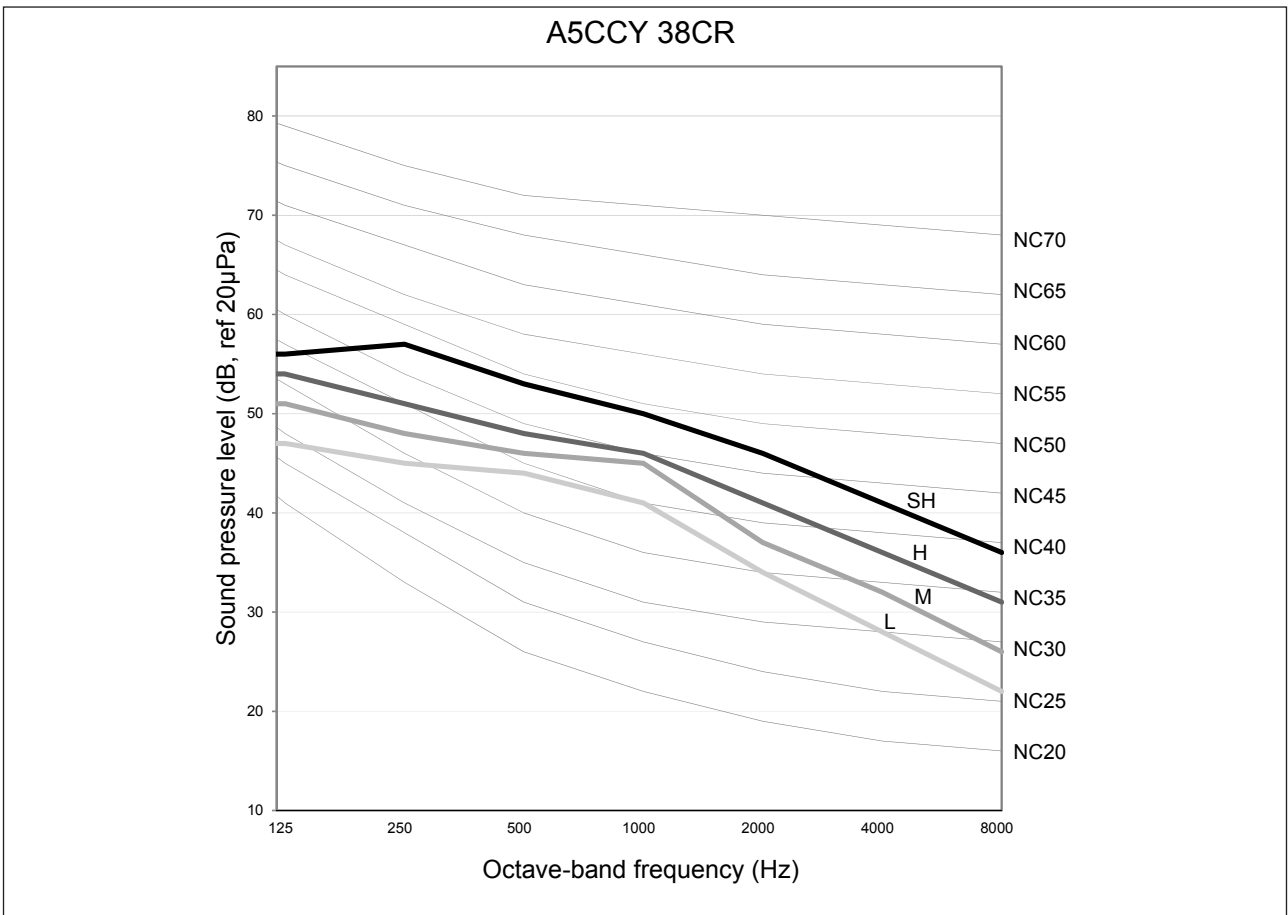

Part Number: 000352103Q3840

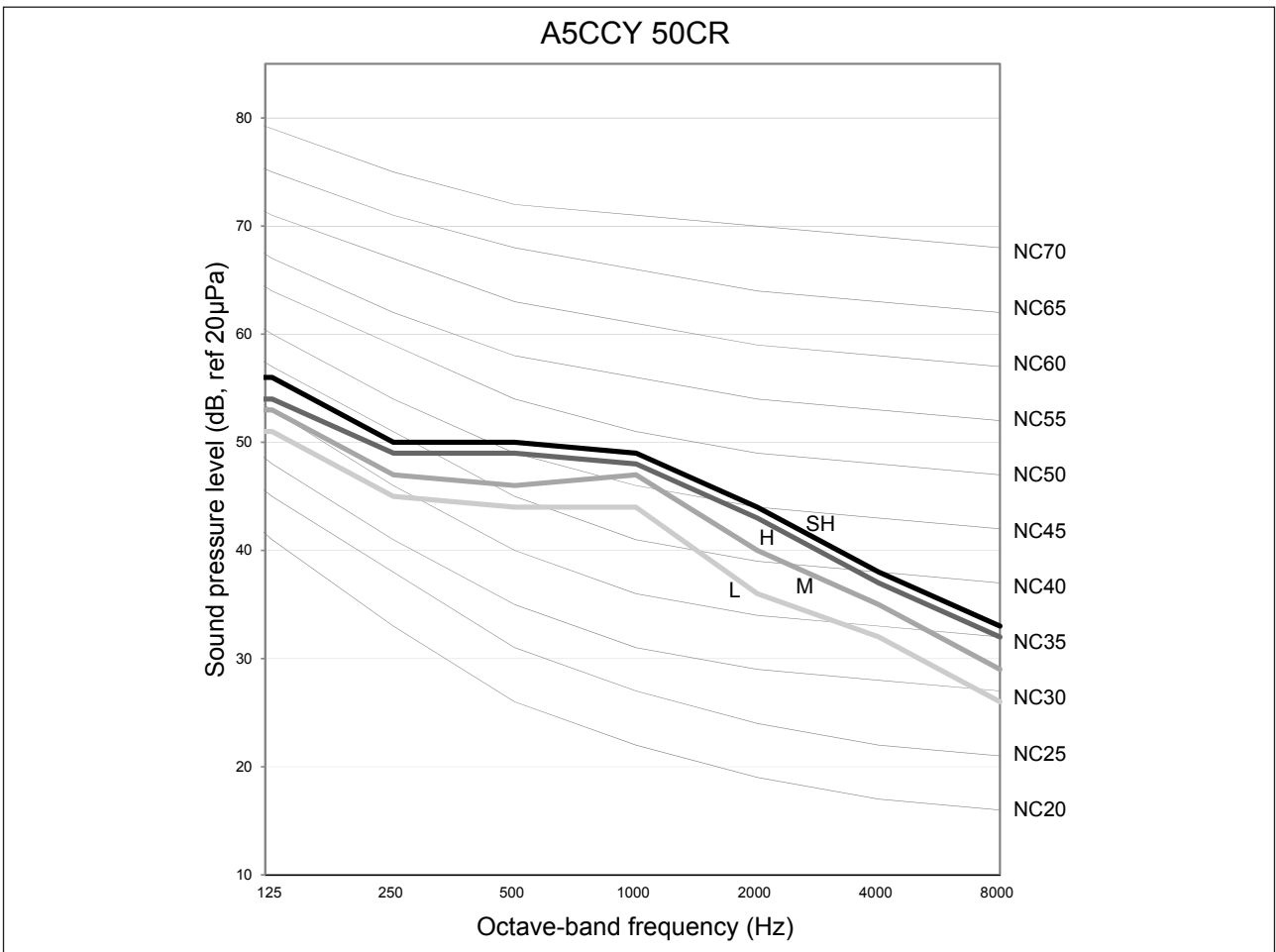

Part Number: 000352103Q5050

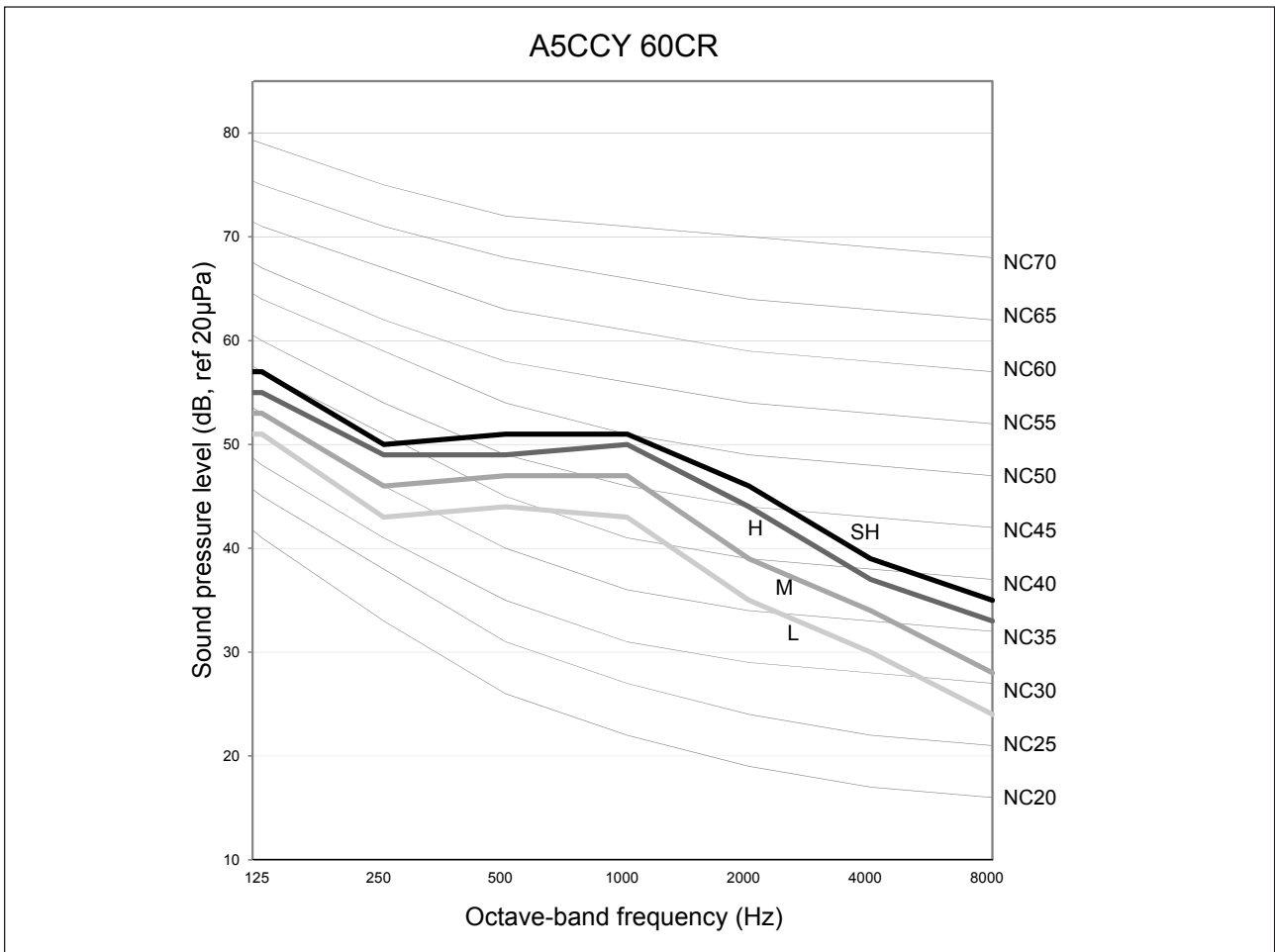

Part Number: 000352103Q6060

Engineering & Physical Data

Engineering Data - A5CKY-ER

MODEL	INDOOR UNIT		A5CKY28ER	A5CKY40ER	A5CKY50ER		
	OUTDOOR UNIT		A5LCY28CR	A5LCY40FR	A5LCY50FR		
NOMINAL COOLING CAPACITY	Btu/h		24200	35900	44400		
	W		7100	10520	13010		
NOMINAL HEATING CAPACITY	Btu/h		28300	40600	48100		
	W		8300	11900	14100		
NOMINAL TOTAL INPUT POWER (COOLING)	W		2212	2740	3900		
NOMINAL TOTAL INPUT POWER (HEATING)	W		2156	3030	3630		
NOMINAL RUNNING CURRENT (COOLING)	W		9.77	12.40	17.70		
NOMINAL RUNNING CURRENT (HEATING)	A		9.53	13.70	16.40		
EER	A		3.21	3.84	3.34		
COP	W/W		3.85	3.93	3.88		
REFRIGERANT CONTROL (EXPANSION DEVICE)			OUTDOOR EXV				
REFRIGERANT CHARGE			1.80	3.95	3.95		
POWER SOURCE			V/Ph/Hz				
REFRIGERANT TYPE			R410A				
INDOOR UNIT	CONTROL		AIR DISCHARGE OPERATION				
	AIR FLOW		AUTOMATIC LOUVER (UP & DOWN)				
			WIRELESS OR WIRED MICRO-COMPUTER REMOTE CONTROL				
			HIGH	l/s / CFM	410 / 860	490 / 1030	780 / 1200
			MEDIUM	l/s / CFM	342 / 725	406 / 860	486 / 1030
			LOW	l/s / CFM	293 / 620	349 / 740	439 / 930
			QUIET	l/s / CFM	250 / 530	293 / 620	368 / 780
	SOUND PRESSURE LEVEL (H/M/L/SL)		dB(A)	41 / 38 / 35 / 32	44 / 41 / 38 / 35	47 / 44 / 43 / 39	
	UNIT DIMENSION		HEIGHT X WIDTH X DEPTH	mm	265 X 820 X 820	300 X 820 X 820	
	WITH PANEL		HEIGHT X WIDTH X DEPTH	mm	340 X 990 X 990	375 X 990 X 990	
	PACKING DIMENSION		HEIGHT X WIDTH X DEPTH	mm	306 X 916 X 916	335 X 916 X 916	
	PANEL		HEIGHT X WIDTH X DEPTH	mm	121 X 1016 X 1000		
	UNIT WEIGHT (UNIT + PANEL)		kg	31 + 4	39 + 4	41 + 4	
	CONDENSATE DRAIN SIZE		mm	19.1	19.1	19.1	
	FAN		TYPE	TURBO			
			DRIVE	DIRECT			
	FAN MOTOR		TYPE	INDUCTION			
			INDEX OF PROTECTION (IP)	IP20			
			INSULATION GRADE	CLASS B			
			RATED INPUT POWER	W	152	176	221
		RATED RUNNING CURRENT	A	0.67	0.79	0.97	
		MOTOR OUTPUT	W	50	60	100	
		POLES	4				
COIL		TUBE	MATERIAL				
			INNER GROOVE COPPER				
		DIAMETER	mm	7.00	7.00	7.00	
		FIN	MATERIAL				
			ALUMINIUM (SLIT FIN)				
		FACE AREA	m ²	0.37	0.48	0.45	
		ROW	3				
		ROW	3				
AIR QUALITY		FILTER	TYPE				
			WASHABLE SARANET FILTER				
		QUANTITY	pc	1	1	1	
CASING		COLOUR	WITHOUT PAINT				
AIR FLOW		l/s / CFM	1786 / 3034	3340 / 5675	3570 / 6065		
SOUND PRESSURE LEVEL		dB(A)	50	50	51		
UNIT DIMENSION		HEIGHT X WIDTH X DEPTH	mm	753 x 940 x 392	1374 x 900 x 320		
PACKING DIMENSION		HEIGHT X WIDTH X DEPTH	mm	793 x 990 x 415	1529 x 1030 x 421		
UNIT WEIGHT		kg	51	100			
PIPE CONNECTION		TYPE	FLARE VALVE				
		SIZE	LIQUID	mm	9.52		
			GAS	mm	15.87		
FAN		TYPE	PROPELLER				
		DRIVE	DIRECT				
FAN MOTOR		TYPE	BRUSHLESS DC MOTOR				
		INDEX OF PROTECTION (IP)	43				
		INSULATION GRADE	CLASS E				
		RATED INPUT POWER	W	79	196	223	
		RATED RUNNING CURRENT	A	0.91	1.26	1.43	
		MOTOR OUTPUT	W	61	70	70	
		POLES	8				
COMPRESSOR		TYPE	HERMETIC SWING	SCROLL			
		OIL TYPE	DAPHNE FVC50K	DAPHNE FVC68D			
		OIL AMOUNT	cm ³	750	1000		
		RATED INPUT POWER (COOLING)	W	NA	893		
		RATED INPUT POWER (HEATING)	W	NA	853		
		RATED RUNNING CURRENT (COOLING)	A	NA	4.19		
		RATED RUNNING CURRENT (HEATING)	A	NA	4.63		
COIL		TUBE	MATERIAL				
			COPPER				
		DIAMETER	mm	7			
		FIN	MATERIAL				
			ALUMINIUM				
		FACE AREA	m ²	0.37	1.14		
		ROW	3				
		ROW	2				
CASING		COLOUR	LIGHT GREY				
DRAWING NUMBER			000452103N2828	000452103P4040	000452103P5050		

ALL UNITS ARE BEING TESTED AND COMPLY TO ISO 5151 (NON-DUCTED UNIT) OR ISO 13253 (DUCTED UNIT).

COOLING	HEATING
INDOOR: 27°C DB / 19°C WB	INDOOR: 20°C DB
OUTDOOR: 35°C DB / 24°C WB	OUTDOOR: 8°C DB / 6°C WB

ALL SPECIFICATIONS ARE SUBJECTED TO CHANGE BY THE MANUFACTURER WITHOUT PRIOR NOTICE.

Engineering Data - A5CMY-ER

MODEL	INDOOR UNIT			A5CMY28ER	A5CMY40ER	A5CMY50ER	R5CMY62CR	
	OUTDOOR UNIT			A5LCY28CR	A5LCY40FR	A5LCY50FR	A5LCY60FR	
NOMINAL COOLING CAPACITY	Btu/h			23200	34100	43000	47800	
	W			6800	10000	12600	14010	
NOMINAL HEATING CAPACITY	Btu/h			26300	38900	52900	54300	
	W			7700	11400	15500	15910	
NOMINAL TOTAL INPUT POWER (COOLING)	W			2420	3280	3600	4880	
NOMINAL TOTAL INPUT POWER (HEATING)	W			2558	2920	4370	4530	
NOMINAL RUNNING CURRENT (COOLING)	A			10.60	14.90	16.30	22.10	
NOMINAL RUNNING CURRENT (HEATING)	A			11.20	13.20	19.60	20.40	
EER	W/W			2.81	3.05	3.50	2.87	
COP	W/W			3.01	3.90	3.55	3.51	
REFRIGERANT CONTROL (EXPANSION DEVICE)				OUTDOOR EXV				
REFRIGERANT CHARGE	kg			1.80	3.95			
POWER SOURCE	V/Ph/Hz			220-240 /1/ 50				
REFRIGERANT TYPE				R410A				
INDOOR UNIT	CONTROL	AIR DISCHARGE OPERATION		AUTOMATIC LOUVER (UP & DOWN)				
	AIR FLOW	HIGH		WIRELESS OR WIRED MICROCOMPUTER REMOTE CONTROL				
		MEDIUM		I/s / CFM	293 / 620	520 / 1100	570 / 1215	732 / 1550
		LOW		I/s / CFM	269 / 570	464 / 983	511 / 1082	651 / 1320
	SOUND PRESSURE LEVEL (H/M/L)			I/s / CFM	245 / 520	414 / 877	453 / 959	472 / 1000
	UNIT DIMENSION	HEIGHT X WIDTH X DEPTH		dBA	56 / 51 / 44	52 / 47 / 46	52 / 50 / 49	56 / 53 / 46
	PACKING DIMENSION	HEIGHT X WIDTH X DEPTH		mm	218 X 1080 X 630	260 X 1538 X 634	260 X 1786 X 634	285 X 1930 X 608
	UNIT WEIGHT			mm	297 X 1197 X 740	330 X 1645 X 724	330 X 1892 X 724	351 X 2016 X 788
	CONDENSATE DRAIN SIZE			kg	27	45	65	70
	FAN	TYPE		19.1				
		DRIVE		SIROCCO				
		TYPE		DIRECT				
		INDEX OF PROTECTION (IP)		INDUCTION				
		INSULATION GRADE		IP20	N/A			
	FAN MOTOR	RATED INPUT POWER		CLASS B		CLASS E		
	RATED RUNNING CURRENT		W	117	190	240	297	
	MOTOR OUTPUT		A	0.52	0.90	1.10	1.30	
	POLES		W	70	118	149	80	
COIL	TUBE	MATERIAL		INNER GROOVE COPPER				
		DIAMETER		PLAIN COPPER				
	FIN	MATERIAL		7.00				
		FACE AREA		ALUMINIUM (SLIT FIN)	HYDROPHILIC (RAISE LANCE)	HYDROPHILIC (RAISE LANCE)	HYDROPHILIC (SLIT FIN)	
	ROW		0.27	0.32	0.38	0.42		
AIR QUALITY	FILTER	TYPE		WASHABLE SARANET FILTER				
		QUANTITY		2	3	2+2	2+3	
CASING			COLOUR	LIGHT GREY				
OUTDOOR UNIT	AIR FLOW	I/s / CFM		1786 / 3034	3340 / 5675	3570 / 6065	3470 / 5896	
	SOUND PRESSURE LEVEL	dBA		50	50	51	51	
	UNIT DIMENSION	HEIGHT X WIDTH X DEPTH		mm	753 x 940 x 392	1374 x 900 x 320		
	PACKING DIMENSION	HEIGHT X WIDTH X DEPTH		mm	793 x 990 x 415	1529 x 1030 x 421		
	UNIT WEIGHT	kg		51	100			
	PIPE CONNECTION	TYPE		FLARE VALVE				
		SIZE	LIQUID	mm	9.52			
		GAS		15.87				
	FAN	TYPE		PROPELLER				
		DRIVE		DIRECT				
	FAN MOTOR	TYPE		BRUSHLESS DC MOTOR				
		INDEX OF PROTECTION (IP)		43				
		INSULATION GRADE		CLASS E				
		RATED INPUT POWER		W	79	196	223	212
		RATED RUNNING CURRENT		A	0.91	1.26	1.43	1.36
	MOTOR OUTPUT		W	61	70	70	70	
	POLES		8					
COMPRESSOR	TYPE		HERMETIC SWING	SCROLL				
	OIL TYPE		DAPHNE FVC50K	DAPHNE FVC68D				
	OIL AMOUNT		cm ³	750	1000			
	RATED INPUT POWER (COOLING)		W	NA	893	893	893	
	RATED INPUT POWER (HEATING)		W	NA	853	853	853	
	RATED RUNNING CURRENT (COOLING)		A	NA	4.19	4.19	4.19	
	RATED RUNNING CURRENT (HEATING)		A	NA	4.63	4.63		
COIL	TUBE	MATERIAL		COPPER				
		DIAMETER		7				
	FIN	MATERIAL		ALUMINIUM				
		FACE AREA		0.37	1.14			
	ROW		3	2				
CASING			COLOUR	LIGHT GREY				
DRAWING NUMBER				000452103M2828	000452103R4040	000452103R5050	000452103CY6260	

ALL UNITS ARE BEING TESTED AND COMPLY TO ISO 5151 (NON-DUCTED UNIT) OR ISO 13253 (DUCTED UNIT).

COOLING	HEATING
INDOOR: 27°C DB / 19°C WB	INDOOR: 20°C DB
OUTDOOR: 35°C DB / 24°C WB	OUTDOOR: 8°C DB / 6°C WB

ALL SPECIFICATIONS ARE SUBJECTED TO CHANGE BY THE MANUFACTURER WITHOUT PRIOR NOTICE.

Engineering Data - A5CCY-CR

MODEL	INDOOR UNIT		A5CCY28CR	A5CCY38CR	A5CCY50CR	A5CCY60CR		
	OUTDOOR UNIT		A5LCY28CR	A5LCY40FR	A5LCY50FR	A5LCY60FR		
NOMINAL COOLING CAPACITY	Btu/h		24200	34800	45400	47800		
	W		7100	10200	13310	14010		
NOMINAL HEATING CAPACITY	Btu/h		27600	38200	53600	56600		
	W		8100	11200	15710	16590		
NOMINAL TOTAL INPUT POWER (COOLING)	W		2212	3220	3960	4600		
NOMINAL TOTAL INPUT POWER (HEATING)	W		2282	2920	4410	4600		
NOMINAL RUNNING CURRENT (COOLING)	A		9.76	14.40	17.90	20.50		
NOMINAL RUNNING CURRENT (HEATING)	A		10.10	12.90	19.90	20.50		
EER	W/W		3.21	3.17	3.65	3.31		
COP	W/W		3.70	3.83	3.87	3.96		
REFRIGERANT CONTROL (EXPANSION DEVICE)	OUTDOOR EXV							
REFRIGERANT CHARGE	kg		1.80	3.95				
POWER SOURCE	V/Ph/Hz		220-240 /1/ 50					
REFRIGERANT TYPE	R410A							
INDOOR UNIT	CONTROL	AIR DISCHARGE OPERATION		DUCTED				
		SUPER HIGH		WIRED MICROCOMPUTER REMOTE CONTROL				
	AIR FLOW	HIGH		l/s / CFM	401 / 850	604 / 1280	675 / 1430	812 / 1720
		MEDIUM		l/s / CFM	330 / 700	547 / 1160	623 / 1320	731 / 1550
		LOW		l/s / CFM	278 / 590	496 / 1050	580 / 1230	632 / 1340
				l/s / CFM	226 / 480	434 / 920	533 / 1130	552 / 1170
	EXTERNAL STATIC PRESSURE (SH/H/M/L)		Pa	78 / 53 / 38 / 25	118 / 96 / 78 / 61	147 / 126 / 109 / 92	147 / 120 / 90 / 69	
	SOUND PRESSURE LEVEL (SH/H/M/L)		dBA	44 / 41 / 38 / 34	55 / 51 / 48 / 45	53 / 52 / 50 / 47	55 / 53 / 50 / 47	
	UNIT DIMENSION	HEIGHT X WIDTH X DEPTH		mm	285 X 1007 X 600	305 X 1302 X 638	378 X 1299 X 541	378 X 1499 X 541
	PACKING DIMENSION	HEIGHT X WIDTH X DEPTH		mm	343 X 1138 X 690	355 X 1461 X 727	415 X 1497 X 631	415 X 1701 X 631
	UNIT WEIGHT			kg	35	47	50	56
	CONDENSATE DRAIN SIZE		mm	19.1				
	FAN	TYPE		SIROCCO				
		DRIVE		DIRECT				
	FAN MOTOR	TYPE		1-Phase Fixed Speed				
INDEX OF PROTECTION (IP)		IP21						
INSULATION GRADE		CLASS B		CLASS E				
RATED INPUT POWER		W	300	503	515	659		
RATED RUNNING CURRENT		A	1.30	0.93	1.07	1.01		
MOTOR OUTPUT		W	320	470	480	600		
POLES		4						
COIL	TUBE	MATERIAL		INNER GROOVE COPPER				
		DIAMETER		mm	7.00			
	FIN	MATERIAL		ALUMINIUM (SLIT FIN)				
		FACE AREA		m ²	0.24	0.35	0.41	0.48
ROW		3						
AIR QUALITY	FILTER	TYPE		WASHABLE SARANET FILTER				
		QUANTITY		pc	2			
CASING		COLOUR	WITHOUT PAINT					
OUTDOOR UNIT	AIR FLOW		l/s / CFM	1786 / 3034	3340 / 5675	3570 / 6065	3470 / 5896	
	SOUND PRESSURE LEVEL		dBA	50	50	51	51	
	UNIT DIMENSION	HEIGHT X WIDTH X DEPTH		mm	753 x 940 x 392	1374 x 900 x 320		
	PACKING DIMENSION	HEIGHT X WIDTH X DEPTH		mm	793 x 990 x 415	1529 x 1030 x 421		
	UNIT WEIGHT			kg	51	100		
	PIPE CONNECTION	TYPE		FLARE VALVE				
		SIZE	LIQUID		mm	9.52		
			GAS		mm	15.87		
	FAN	TYPE		PROPELLER				
		DRIVE		DIRECT				
	FAN MOTOR	TYPE		BRUSHLESS DC MOTOR				
		INDEX OF PROTECTION (IP)		43				
		INSULATION GRADE		CLASS E				
		RATED INPUT POWER		W	79	196	223	212
		RATED RUNNING CURRENT		A	0.91	1.26	1.43	1.36
MOTOR OUTPUT		W	61	70	70	70		
POLES		8						
COMPRESSOR	TYPE		HERMETIC SWING	SCROLL				
	OIL TYPE		DAHPNE FVC50K	DAHPNE FVC68D				
	OIL AMOUNT		cm ³	750	1000			
	RATED INPUT POWER (COOLING)		W	NA	893	893	893	
	RATED INPUT POWER (HEATING)		W	NA	853	853	853	
	RATED RUNNING CURRENT (COOLING)		A	NA	4.19	4.19	4.19	
RATED RUNNING CURRENT (HEATING)		A	NA	4.63	4.63	4.63		
COIL	TUBE	MATERIAL		COPPER				
		DIAMETER		mm	7			
	FIN	MATERIAL		ALUMINIUM				
		FACE AREA		m ²	0.37	1.14		
ROW		3						
CASING		COLOUR	LIGHT GREY					
DRAWING NUMBER			000452103K2828	000452103Q3840	000452103Q5050	000452103Q6060		

ALL UNITS ARE BEING TESTED AND COMPLY TO ISO 5151 (NON-DUCTED UNIT) OR ISO 13253 (DUCTED UNIT).

COOLING	HEATING
INDOOR: 27°C DB / 19°C WB	INDOOR: 20°C DB
OUTDOOR: 35°C DB / 24°C WB	OUTDOOR: 8°C DB / 6°C WB

ALL SPECIFICATIONS ARE SUBJECTED TO CHANGE BY THE MANUFACTURER WITHOUT PRIOR NOTICE.

Engineering Data - A5CKY-ER (3 phase)

MODEL	INDOOR UNIT		A5CKY40ER	A5CKY50ER
	OUTDOOR UNIT		A5LCY40FR	A5LCY50FR
NOMINAL COOLING CAPACITY	Btu/h		35800	42600
	W		10500	12500
NOMINAL HEATING CAPACITY	Btu/h		38200	47700
	W		11200	14000.00
NOMINAL TOTAL INPUT POWER (COOLING)	W		3070	3880
NOMINAL TOTAL INPUT POWER (HEATING)	W		3100	3860
NOMINAL RUNNING CURRENT (COOLING)	W		4.85	6.04
NOMINAL RUNNING CURRENT (HEATING)	A		4.91	6.15
EER	A		3.42	3.22
COP	W/W		3.60	3.63
REFRIGERANT CONTROL (EXPANSION DEVICE)			OUTDOOR EXV	
REFRIGERANT CHARGE			kg	
POWER SOURCE			V/Ph/Hz	
REFRIGERANT TYPE			R410A	
CONTROL	AIR DISCHARGE OPERATION		AUTOMATIC LOUVER (UP & DOWN)	
			WIRED OR WIRELESS REMOTE CONTROL	
AIR FLOW	HIGH	l/s / CFM	490 / 1030	780 / 1200
	MEDIUM	l/s / CFM	406 / 860	486 / 1030
	LOW	l/s / CFM	349 / 740	439 / 930
	QUIET	l/s / CFM	293 / 620	368 / 780
SOUND PRESSURE LEVEL (H/M/L/SL)		dBA	44 / 41 / 38 / 35	47 / 44 / 43 / 39
UNIT DIMENSION	HEIGHT X WIDTH X DEPTH		mm	
WITH PANEL	HEIGHT X WIDTH X DEPTH		mm	
PACKING DIMENSION	HEIGHT X WIDTH X DEPTH		mm	
PANEL	HEIGHT X WIDTH X DEPTH		mm	
UNIT WEIGHT (UNIT + PANEL)		kg	39 + 4	41 + 4
CONDENSATE DRAIN SIZE		mm	19.1	
FAN	TYPE		TURBO	
	DRIVE		DIRECT	
FAN MOTOR	TYPE		INDUCTION	
	INDEX OF PROTECTION (IP)		IP20	
	INSULATION GRADE		CLASS B	
	RATED INPUT POWER	W	176	221
	RATED RUNNING CURRENT	A	0.79	0.97
	MOTOR OUTPUT	W	60	100
POLES		4		
COIL	TUBE	MATERIAL	INNER GROOVE COPPER	
		DIAMETER	mm	
	FIN	MATERIAL	ALUMINIUM (SLIT FIN)	
		FACE AREA	m ²	0.48
ROW		3		
AIR QUALITY	FILTER	TYPE	WASHABLE SARANET FILTER	
		QUANTITY	pc	
CASING		COLOUR	WITHOUT PAINT	
AIR FLOW		l/s / CFM	1553 / 3290	1534 / 3250
SOUND PRESSURE LEVEL		dBA	50	51
UNIT DIMENSION	HEIGHT X WIDTH X DEPTH		mm	
PACKING DIMENSION	HEIGHT X WIDTH X DEPTH		mm	
UNIT WEIGHT		kg	100	
PIPE CONNECTION	TYPE		FLARE VALVE	
	SIZE	LIQUID	mm	
		GAS	mm	
FAN	TYPE		PROPELLER	
	DRIVE		DIRECT	
FAN MOTOR	TYPE		BRUSHLESS DC MOTOR	
	INDEX OF PROTECTION (IP)		43	
	INSULATION GRADE		CLASS E	
	RATED INPUT POWER	W	145	141
	RATED RUNNING CURRENT	A	1.30	1.26
	MOTOR OUTPUT	W	70	
POLES		8		
COMPRESSOR	TYPE		SCROLL	
	OIL TYPE		DAPHNE FVC68D	
	OIL AMOUNT	cm ³	1000	
	RATED INPUT POWER (COOLING)	W	NA	
	RATED INPUT POWER (HEATING)	W	NA	
	RATED RUNNING CURRENT (COOLING)	A	NA	
RATED RUNNING CURRENT (HEATING)	A	NA		
COIL	TUBE	MATERIAL	COPPER	
		DIAMETER	mm	
	FIN	MATERIAL	ALUMINIUM	
		FACE AREA	m ²	1.14
ROW		2		
CASING		COLOUR	LIGHT GREY	
DRAWING NUMBER			000452203P4040	000452203P5050

ALL UNITS ARE BEING TESTED AND COMPLY TO ISO 5151 (NON-DUCTED UNIT) OR ISO 13253 (DUCTED UNIT).

COOLING	HEATING
INDOOR: 27°C DB / 19°C WB	INDOOR: 20°C DB
OUTDOOR: 35°C DB / 24°C WB	OUTDOOR: 8°C DB / 6°C WB

ALL SPECIFICATIONS ARE SUBJECTED TO CHANGE BY THE MANUFACTURER WITHOUT PRIOR NOTICE.

Engineering Data - A5CMY-ER (3 phase)

MODEL	INDOOR UNIT			A5CMY40ER	A5CMY50ER	R5CMY62CR		
	OUTDOOR UNIT			A5LCY40FR	A5LCY50FR	A5LCY60FR		
NOMINAL COOLING CAPACITY				Btu/h	34100	42600	44300	
				W	10000	12500	13000	
NOMINAL HEATING CAPACITY				Btu/h	38200	47700	52800	
				W	11200	14000	15500	
NOMINAL TOTAL INPUT POWER (COOLING)				W	3100	4150	4890	
NOMINAL TOTAL INPUT POWER (HEATING)				W	3100	3880	4290	
NOMINAL RUNNING CURRENT (COOLING)				A	4.86	6.47	7.54	
NOMINAL RUNNING CURRENT (HEATING)				A	5.02	6.06	6.64	
EER				W/W	3.23	3.01	2.66	
COP				W/W	3.61	3.61	3.61	
REFRIGERANT CONTROL (EXPANSION DEVICE)				OUTDOOR EXV				
REFRIGERANT CHARGE				kg	4.30			
POWER SOURCE				V/Ph/Hz	380-415 /3/ 50			
REFRIGERANT TYPE				R410A				
INDOOR UNIT	CONTROL	AIR DISCHARGE OPERATION			AUTOMATIC LOUVER (UP & DOWN)			
	AIR FLOW	HIGH			WIRED OR WIRELESS REMOTE CONTROL			
		MEDIUM			l/s / CFM	520 / 1100	570 / 1215	732 / 1550
		LOW			l/s / CFM	464 / 983	511 / 1082	651 / 1320
	SOUND PRESSURE LEVEL (H/M/L)				l/s / CFM	414 / 877	453 / 959	472 / 1000
	UNIT DIMENSION	HEIGHT X WIDTH X DEPTH			dBA	52 / 47 / 46	52 / 50 / 49	56 / 53 / 46
	PACKING DIMENSION	HEIGHT X WIDTH X DEPTH			mm	260 X 1538 X 634	260 X 1786 X 634	285 X 1930 X 608
	UNIT WEIGHT				mm	330 X 1645 X 724	330 X 1892 X 724	351 X 2016 X 788
	CONDENSATE DRAIN SIZE				kg	45	65	70
	FAN	TYPE			19.1			
		DRIVE			SIROCCO			
	FAN MOTOR	TYPE			INDUCTION			
		INDEX OF PROTECTION (IP)			N/A			
		INSULATION GRADE			CLASS B		CLASS E	
		RATED INPUT POWER			W	190	240	297
		RATED RUNNING CURRENT			A	0.90	1.10	1.30
		MOTOR OUTPUT			W	118	149	80
	COIL	POLES			4			
		TUBE	MATERIAL		INNER GROOVE COPPER			
			DIAMETER		mm	7.00		PLAIN COPPER
FIN		MATERIAL		HYDROPHILIC (RAISE LANCE)				
		FACE AREA		m²	0.32	0.38	HYDROPHILIC (SLIT FIN)	
	ROW			3	4	0.42		
AIR QUALITY	FILTER	TYPE		WASHABLE SARANET FILTER				
		QUANTITY		pc	3	2+2	2+3	
CASING				COLOUR	LIGHT GREY			
OUTDOOR UNIT	AIR FLOW				l/s / CFM	1553 / 3290	1534 / 3250	
	SOUND PRESSURE LEVEL				dBA	50	51	
	UNIT DIMENSION	HEIGHT X WIDTH X DEPTH			mm	1374 x 900 x 320		
	PACKING DIMENSION	HEIGHT X WIDTH X DEPTH			mm	1529 x 1030 x 421		
	UNIT WEIGHT				kg	100		
	PIPE CONNECTION	TYPE			FLARE VALVE			
		SIZE	LIQUID		mm	9.52		
			GAS		mm	15.87		
	FAN	TYPE			PROPELLER			
		DRIVE			DIRECT			
	FAN MOTOR	TYPE			BRUSHLESS DC MOTOR			
		INDEX OF PROTECTION (IP)			43			
		INSULATION GRADE			CLASS E			
		RATED INPUT POWER			W	145	141	
		RATED RUNNING CURRENT			A	1.30	1.26	
		MOTOR OUTPUT			W	70		
	COMPRESSOR	POLES			8			
		TYPE			SCROLL			
		OIL TYPE			DAPHNE FVC68D			
		OIL AMOUNT			cm³	1000		
RATED INPUT POWER (COOLING)			W	NA				
RATED INPUT POWER (HEATING)			W	NA				
RATED RUNNING CURRENT (COOLING)			A	NA				
COIL	RATED RUNNING CURRENT (HEATING)			A	NA			
	TUBE	MATERIAL		COPPER				
		DIAMETER		mm	7			
	FIN	MATERIAL		ALUMINIUM				
FACE AREA		m²	1.14					
CASING				ROW	2			
				COLOUR	LIGHT GREY			
DRAWING NUMBER				000452203R4040	000452203R5050	000452203CY6260		

ALL UNITS ARE BEING TESTED AND COMPLY TO ISO 5151 (NON-DUCTED UNIT) OR ISO 13253 (DUCTED UNIT).

COOLING	HEATING
INDOOR: 27°C DB / 19°C WB	INDOOR: 20°C DB
OUTDOOR: 35°C DB / 24°C WB	OUTDOOR: 8°C DB / 6°C WB

ALL SPECIFICATIONS ARE SUBJECTED TO CHANGE BY THE MANUFACTURER WITHOUT PRIOR NOTICE.

Engineering Data - A5CCY-CR (3 phase)

MODEL	INDOOR UNIT		A5CCY38CR	A5CCY50CR	A5CCY60CR	
	OUTDOOR UNIT		A5LCY40FR	A5LCY50FR	A5LCY60FR	
NOMINAL COOLING CAPACITY	Btu/h		34800	43300	47700	
	W		10200	12700	14000	
NOMINAL HEATING CAPACITY	Btu/h		38200	47700	56200	
	W		11200	14000	16500	
NOMINAL TOTAL INPUT POWER (COOLING)	W		3320	4270	4970	
NOMINAL TOTAL INPUT POWER (HEATING)	W		3260	4280	4970	
NOMINAL RUNNING CURRENT (COOLING)	A		5.20	6.54	7.61	
NOMINAL RUNNING CURRENT (HEATING)	A		5.12	6.64	7.67	
EER	W/W		3.07	2.97	2.82	
COP	W/W		3.44	3.27	3.32	
REFRIGERANT CONTROL (EXPANSION DEVICE)	OUTDOOR EXV					
REFRIGERANT CHARGE	kg		4.30			
POWER SOURCE	V/Ph/Hz		380-415 /3/ 50			
REFRIGERANT TYPE	R410A					
INDOOR UNIT	CONTROL	AIR DISCHARGE OPERATION		DUCTED		
	AIR FLOW	SUPER HIGH		WIRED MICROCOMPUTER REMOTE CONTROL		
		HIGH		604 / 1280	675 / 1430	812 / 1720
		MEDIUM		547 / 1160	623 / 1320	731 / 1550
		LOW		496 / 1050	580 / 1230	632 / 1340
	EXTERNAL STATIC PRESSURE (SH/H/M/L)	Pa		118 / 96 / 78 / 61	147 / 126 / 109 / 92	147 / 120 / 90 / 69
	SOUND PRESSURE LEVEL (SH/H/M/L)	dBA		55 / 51 / 48 / 45	53 / 52 / 50 / 47	55 / 53 / 50 / 47
	UNIT DIMENSION	HEIGHT X WIDTH X DEPTH		305 X 1302 X 638	378 X 1299 X 541	378 X 1499 X 541
	PACKING DIMENSION	HEIGHT X WIDTH X DEPTH		355 X 1461 X 727	415 X 1497 X 631	415 X 1701 X 631
	UNIT WEIGHT	kg		47	50	56
	CONDENSATE DRAIN SIZE	mm		19.1		
	FAN	TYPE		SIROCCO		
		DRIVE		DIRECT		
	FAN MOTOR	TYPE		1-Phase Fixed Speed		
		INDEX OF PROTECTION (IP)		IP21		
		INSULATION GRADE		CLASS B		CLASS E
		RATED INPUT POWER	W	503	515	659
		RATED RUNNING CURRENT	A	0.93	1.07	1.01
		MOTOR OUTPUT	W	470	480	600
	COIL	TUBE	MATERIAL		INNER GROOVE COPPER	
DIAMETER			7.00			
FIN		MATERIAL		ALUMINIUM (SLIT FIN)		
		FACE AREA		0.35	0.41	0.48
AIR QUALITY	FILTER	TYPE		WASHABLE SARANET FILTER		
CASING	COLOUR		WITHOUT PAINT			
OUTDOOR UNIT	AIR FLOW	l/s / CFM		1553 / 3290	1534 / 3250	
	SOUND PRESSURE LEVEL	dBA		50	51	
	UNIT DIMENSION	HEIGHT X WIDTH X DEPTH		1374 x 900 x 320		
	PACKING DIMENSION	HEIGHT X WIDTH X DEPTH		1529 x 1030 x 421		
	UNIT WEIGHT	kg		100		
	PIPE CONNECTION	SIZE	TYPE		FLARE VALVE	
			LIQUID		9.52	
			GAS		15.87	
	FAN	TYPE		PROPELLER		
		DRIVE		DIRECT		
	FAN MOTOR	TYPE		BRUSHLESS DC MOTOR		
		INDEX OF PROTECTION (IP)		43		
		INSULATION GRADE		CLASS E		
		RATED INPUT POWER	W	145	141	
		RATED RUNNING CURRENT	A	1.30	1.26	
		MOTOR OUTPUT	W	70		
	COMPRESSOR	POLES		8		
		TYPE		SCROLL		
		OIL TYPE		DAPHNE FVC68D		
		OIL AMOUNT		1000		
RATED INPUT POWER (COOLING)		W	NA			
RATED INPUT POWER (HEATING)		W	NA			
COIL	TUBE	MATERIAL		COPPER		
		DIAMETER		7		
	FIN	MATERIAL		ALUMINIUM		
		FACE AREA		1.14		
CASING	COLOUR		LIGHT GREY			
DRAWING NUMBER			000452203Q3840	000452203Q5050	000452203Q6060	

ALL UNITS ARE BEING TESTED AND COMPLY TO ISO 5151 (NON-DUCTED UNIT) OR ISO 13253 (DUCTED UNIT).

COOLING	HEATING
INDOOR: 27°C DB / 19°C WB	INDOOR: 20°C DB
OUTDOOR: 35°C DB / 24°C WB	OUTDOOR: 8°C DB / 6°C WB

ALL SPECIFICATIONS ARE SUBJECTED TO CHANGE BY THE MANUFACTURER WITHOUT PRIOR NOTICE.

Safety Device

MODEL	INDOOR		A5CKY 28ER	A5CKY 40ER	A5CKY 50ER
	OUTDOOR		A5LCY 28CR	A5LCY 40FR	A5LCY 50FR
SAFETY DEVICE	HIGH PRESSURE SWITCH	TYPE		NC	
		OPEN	kPa / psi	4137 / 600	
		CLOSE	kPa / psi	3309 / 480	
	LOW PRESSURE SWITCH	TYPE		NC	
		OPEN	kPa / psi	120 / 17.4	
		CLOSE	kPa / psi	200 / 29	
	PHASE SEQUENCER			NA	
DISC. THERMOSTAT SETTING		°C / F	NA		
PART NUMBER			000552003N2828	000552003P4040	000552003P5050

MODEL	INDOOR		A5CMY 28ER	A5CMY 40ER	A5CMY 50ER	A5CMY 62CR
	OUTDOOR		A5LCY 28CR	A5LCY 40FR	A5LCY 50FR	A5LCY 60FR
SAFETY DEVICE	HIGH PRESSURE SWITCH	TYPE		NC		
		OPEN	kPa / psi	4137 / 600		
		CLOSE	kPa / psi	3309 / 480		
	LOW PRESSURE SWITCH	TYPE		NC		
		OPEN	kPa / psi	120 / 17.4		
		CLOSE	kPa / psi	200 / 29		
	PHASE SEQUENCER			NA		
DISC. THERMOSTAT SETTING		°C / F	NA			
PART NUMBER			000552003 M2828	000552003 R2828	000552003 R5050	000552003 CY6260

MODEL	INDOOR		A5CCY 28CR	A5CCY 38CR	A5CCY 50CR	A5CCY 60CR
	OUTDOOR		A5LCY 28CR	A5LCY 40FR	A5LCY 50FR	A5LCY 60FR
SAFETY DEVICE	HIGH PRESSURE SWITCH	TYPE		NC		
		OPEN	kPa / psi	4137 / 600		
		CLOSE	kPa / psi	3309 / 480		
	LOW PRESSURE SWITCH	TYPE		NC		
		OPEN	kPa / psi	120 / 17.4		
		CLOSE	kPa / psi	200 / 29		
	PHASE SEQUENCER			NA		
DISC. THERMOSTAT SETTING		°C / F	NA			
PART NUMBER			000552003 K2828	000552003 Q3840	000552003 Q5050	000552003 Q6060

ALL SPECIFICATIONS ARE SUBJECTED TO CHANGE BY THE MANUFACTURER WITHOUT PRIOR NOTICE.

Outlines & Dimensions

Indoor Unit

Model: A5CKY 28/40/50ER

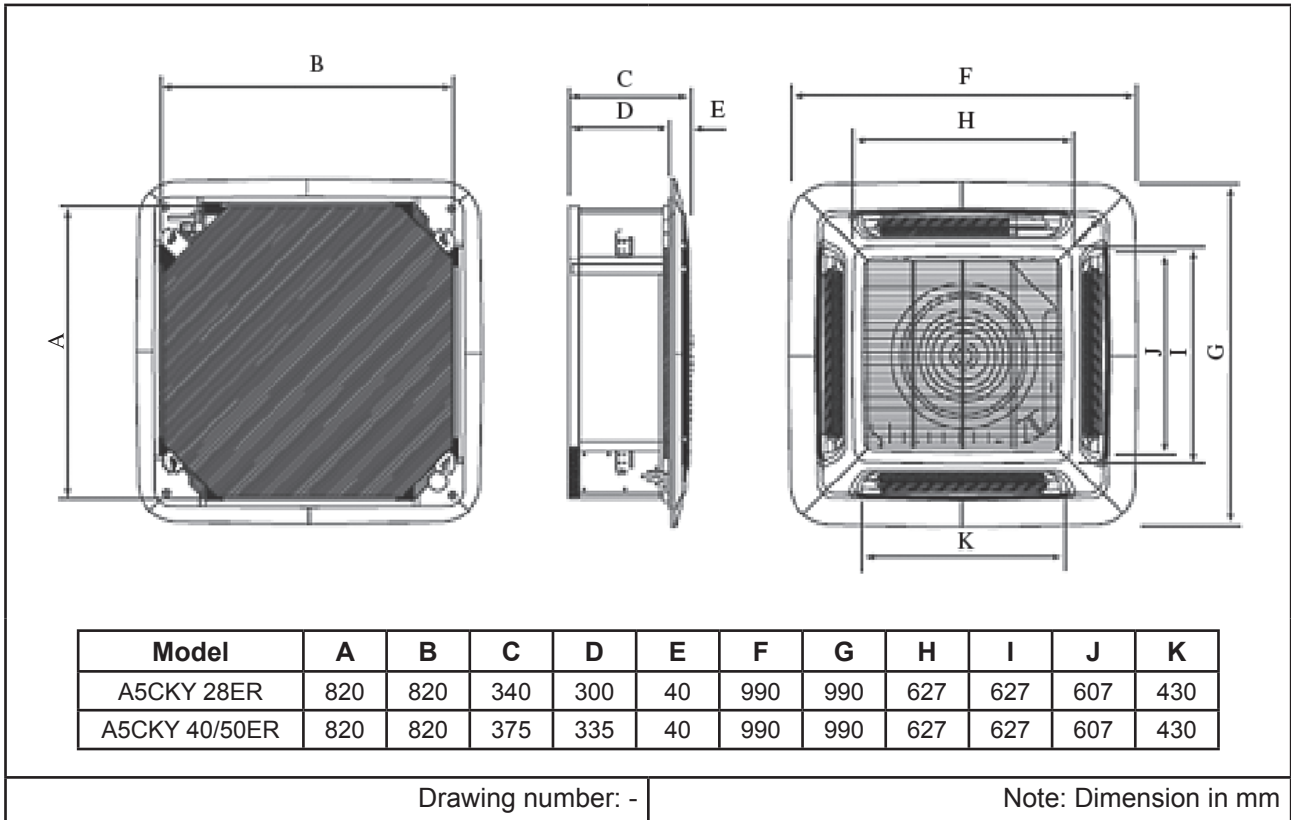

Indoor Unit

Model: A5CMY 28ER

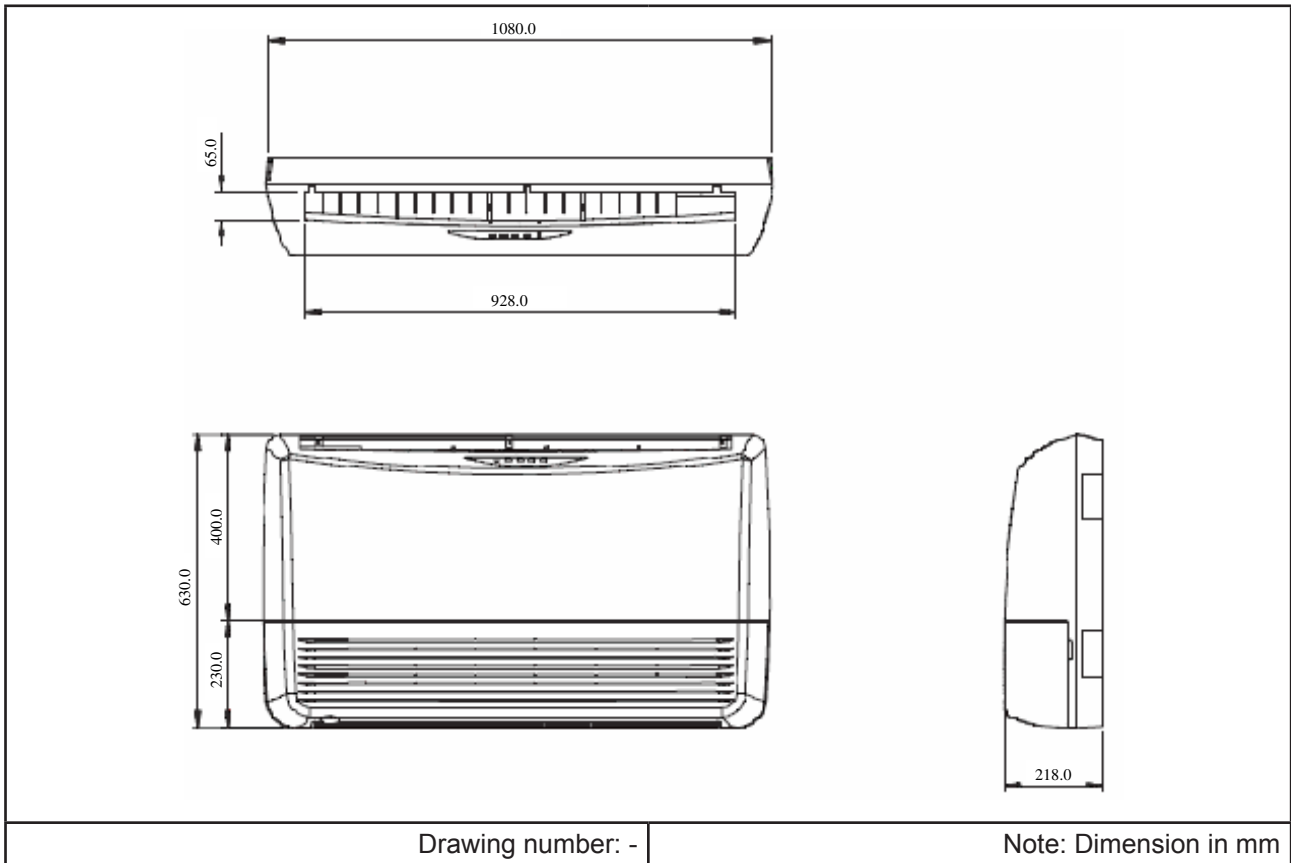

Indoor Unit
Model: A5CMY 40/50ER

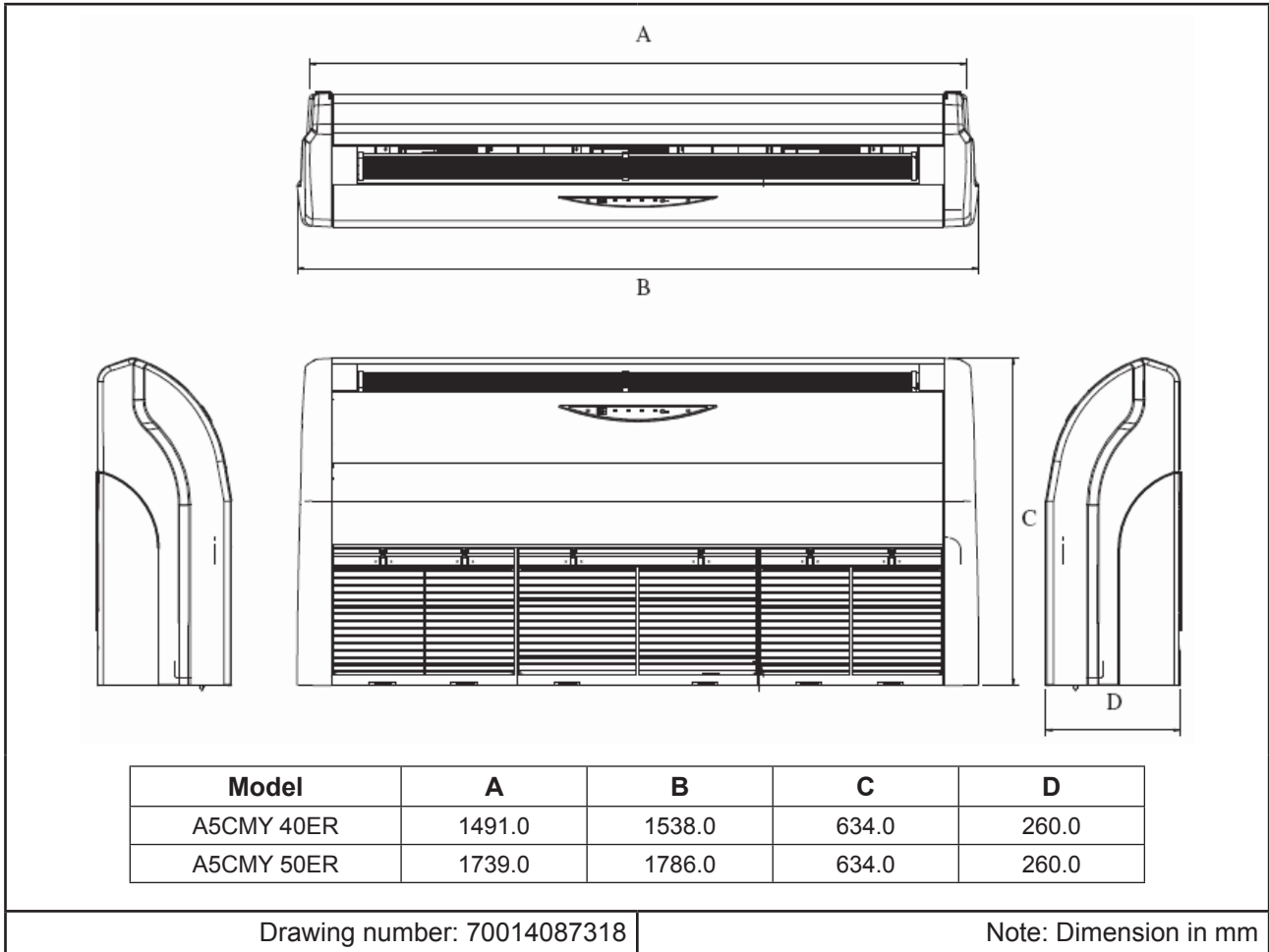

Indoor Unit
Model: A5CMY 62CR

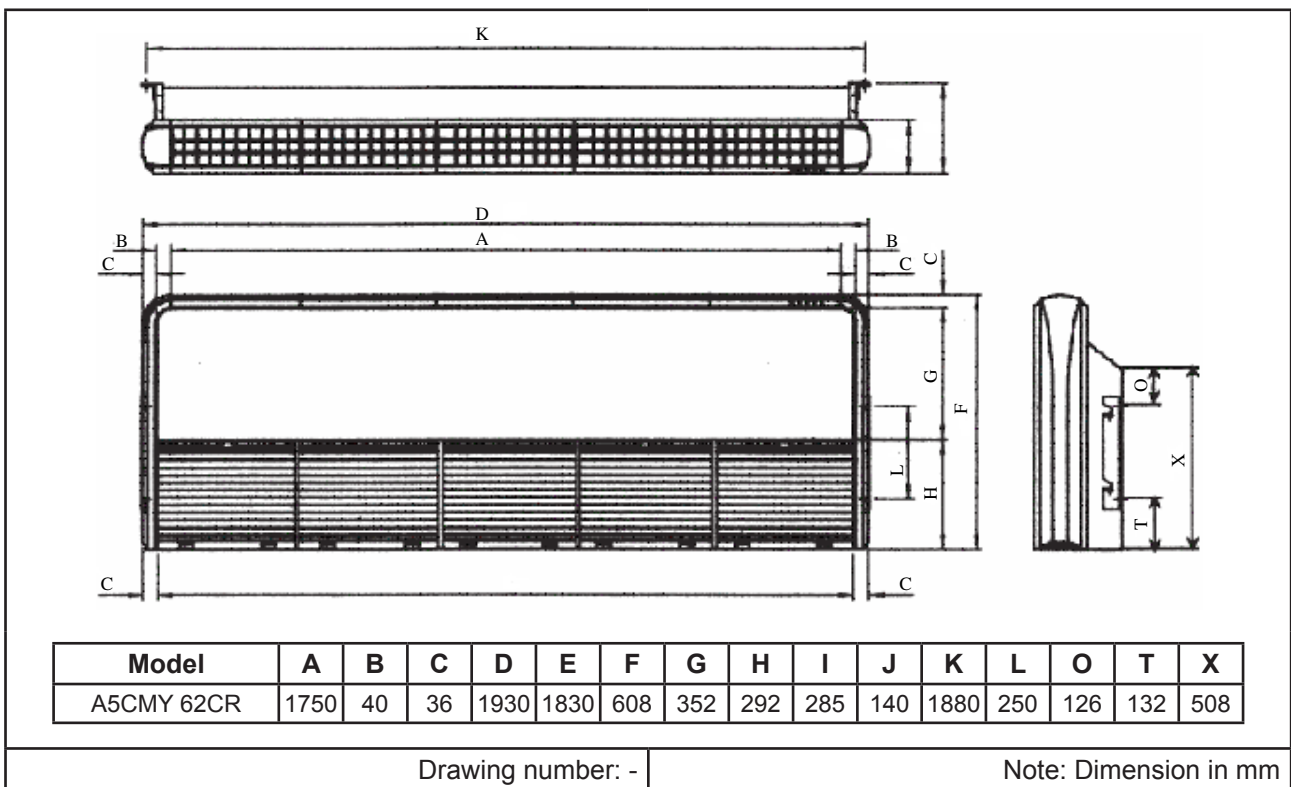

Indoor Unit

Model: A5CCY 28/38/50/60CR

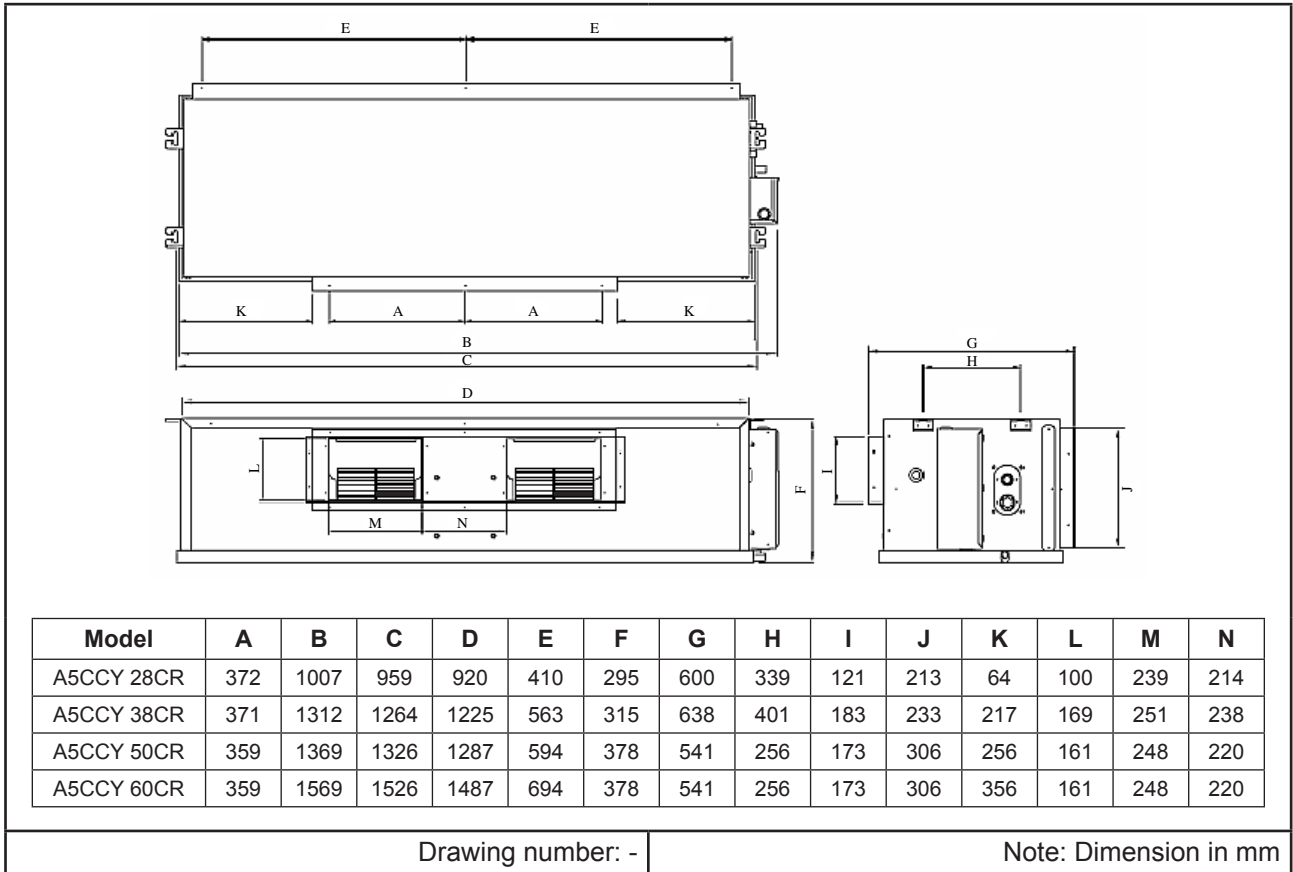

Outdoor Unit

Model: A5LCY 28CR

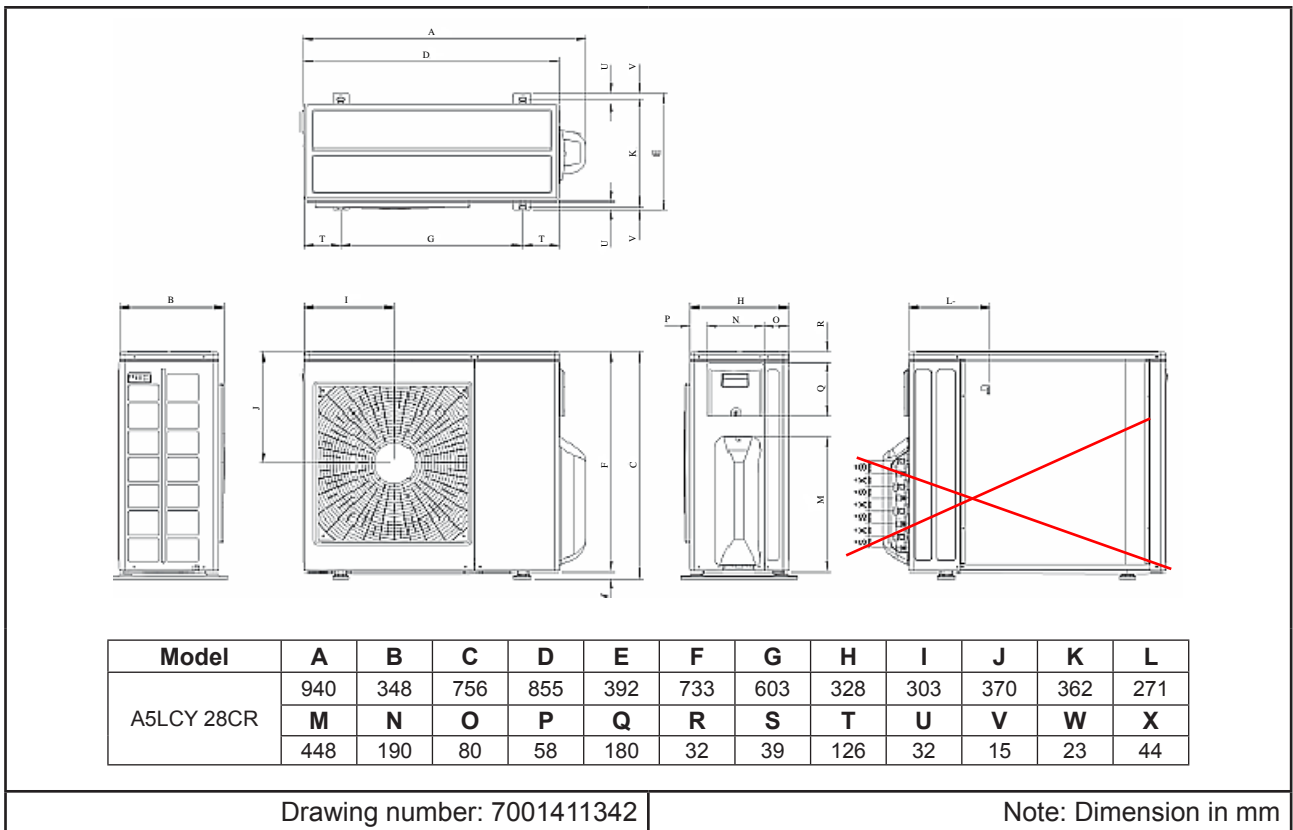

Outdoor Unit
Model: A5LCY 40/50/60FR

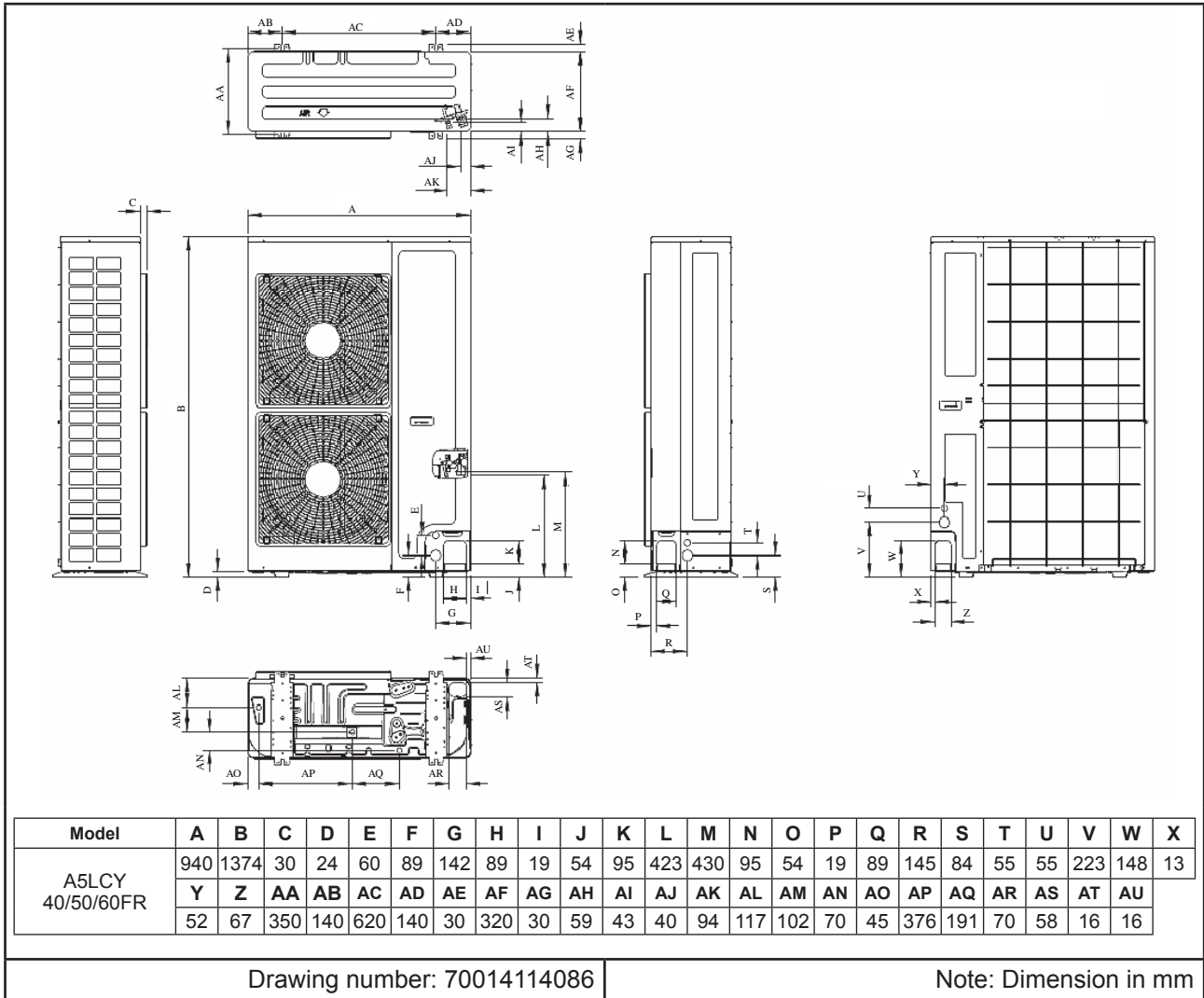

Wiring Diagrams

Indoor Unit
Model: A5CKY 28ER

Outdoor Unit
Model: A5LCY 28CR

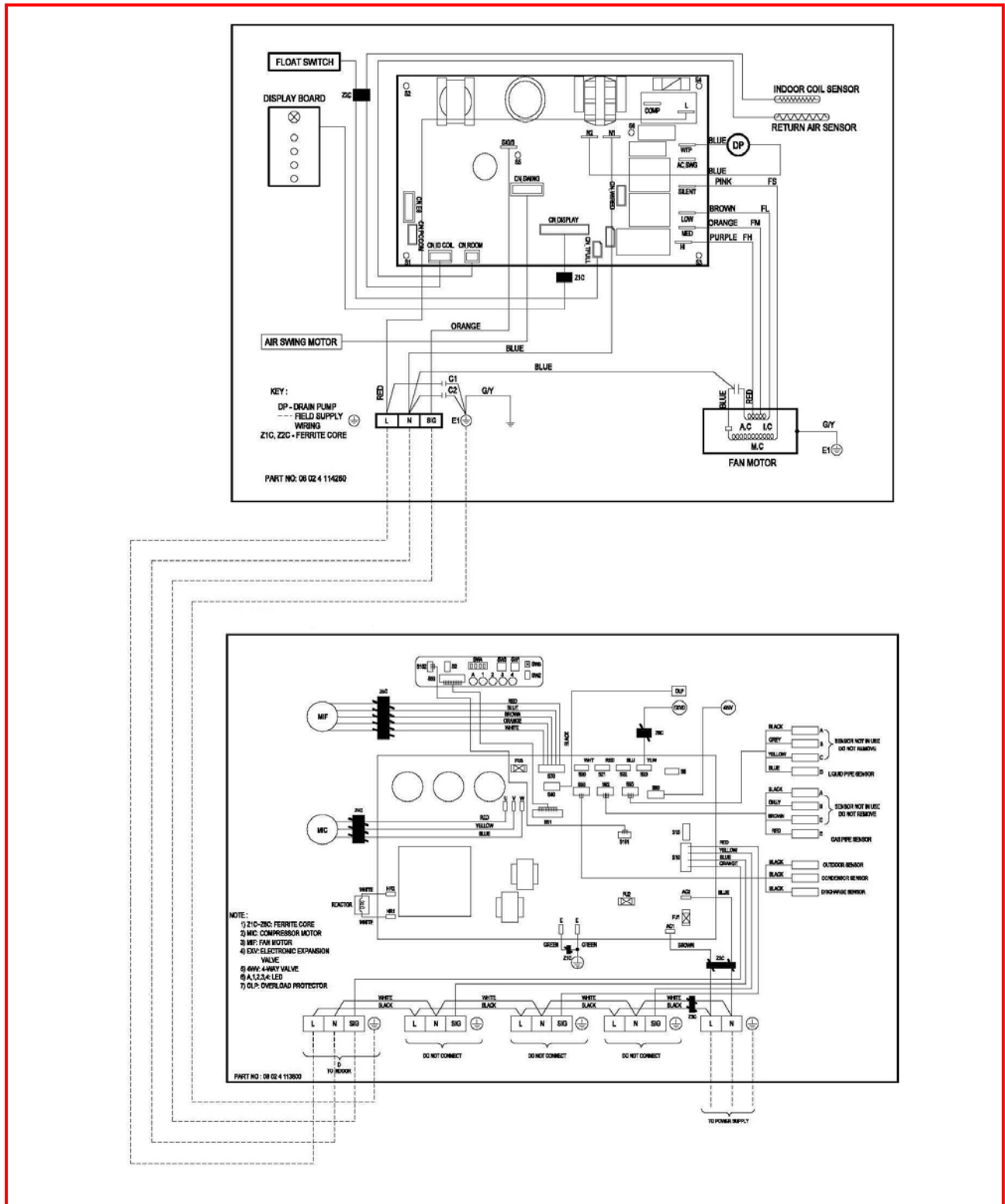

Drawing number: 4114395

Indoor Unit
Model: A5CKY 40/50ER

Outdoor Unit
Model: A5LCY 40/50FR

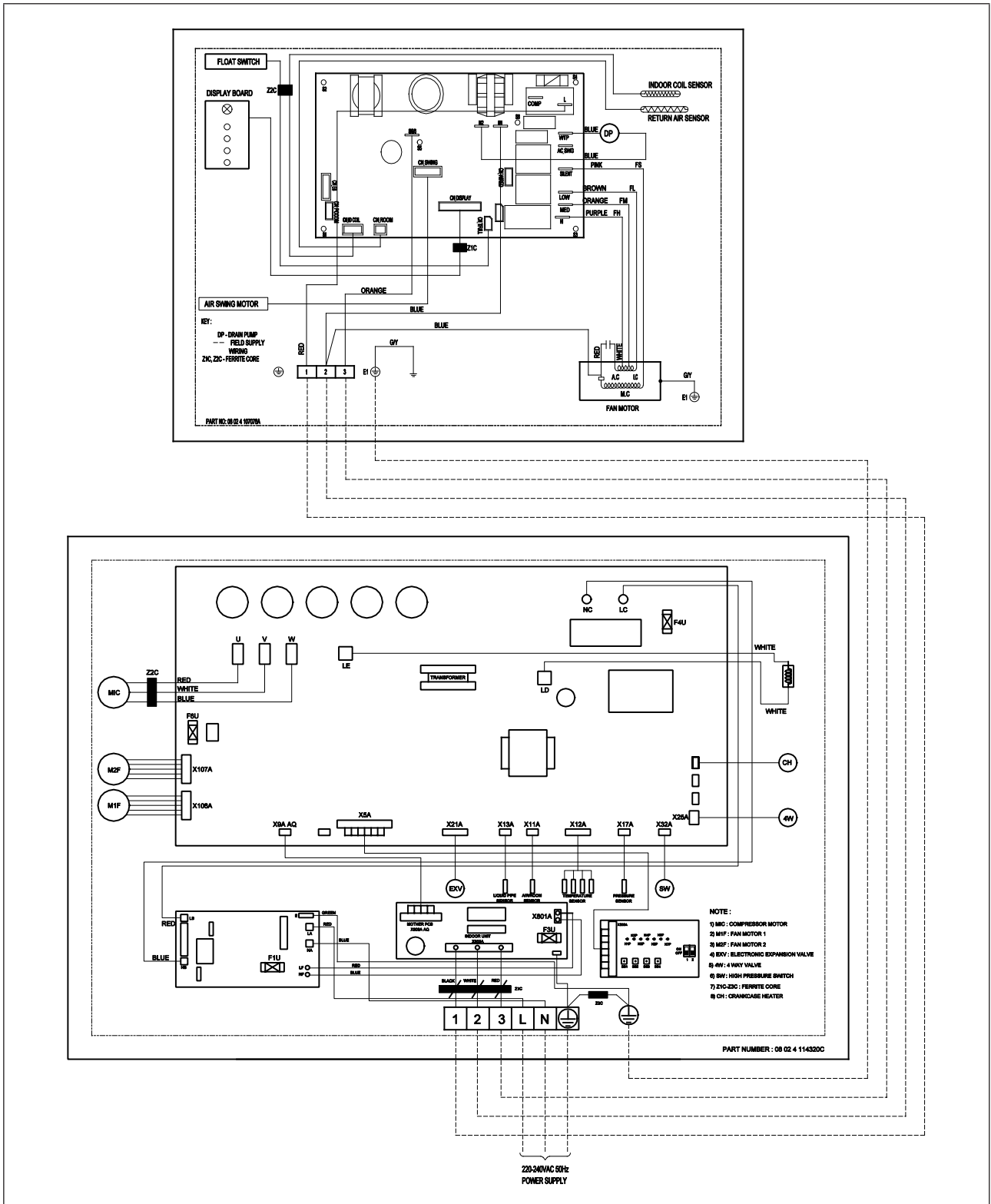

Drawing number: 4109275

Indoor Unit
Model: A5CMY 28ER

Outdoor Unit
Model: A5LCY 28CR

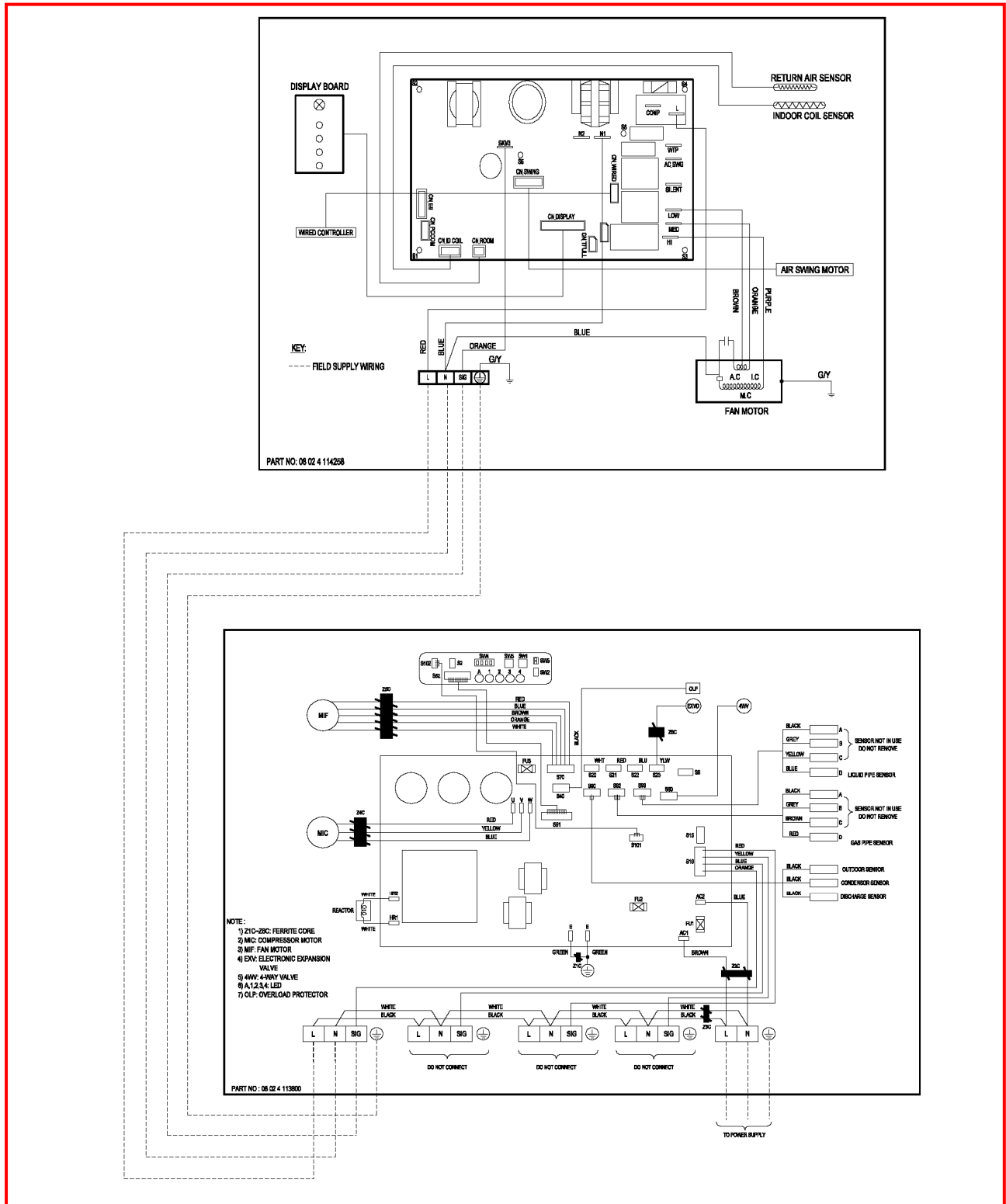

Drawing number: 4114397

Indoor Unit
Model: A5CMY 40/50ER

Outdoor Unit
Model: A5LCY 40/50FR

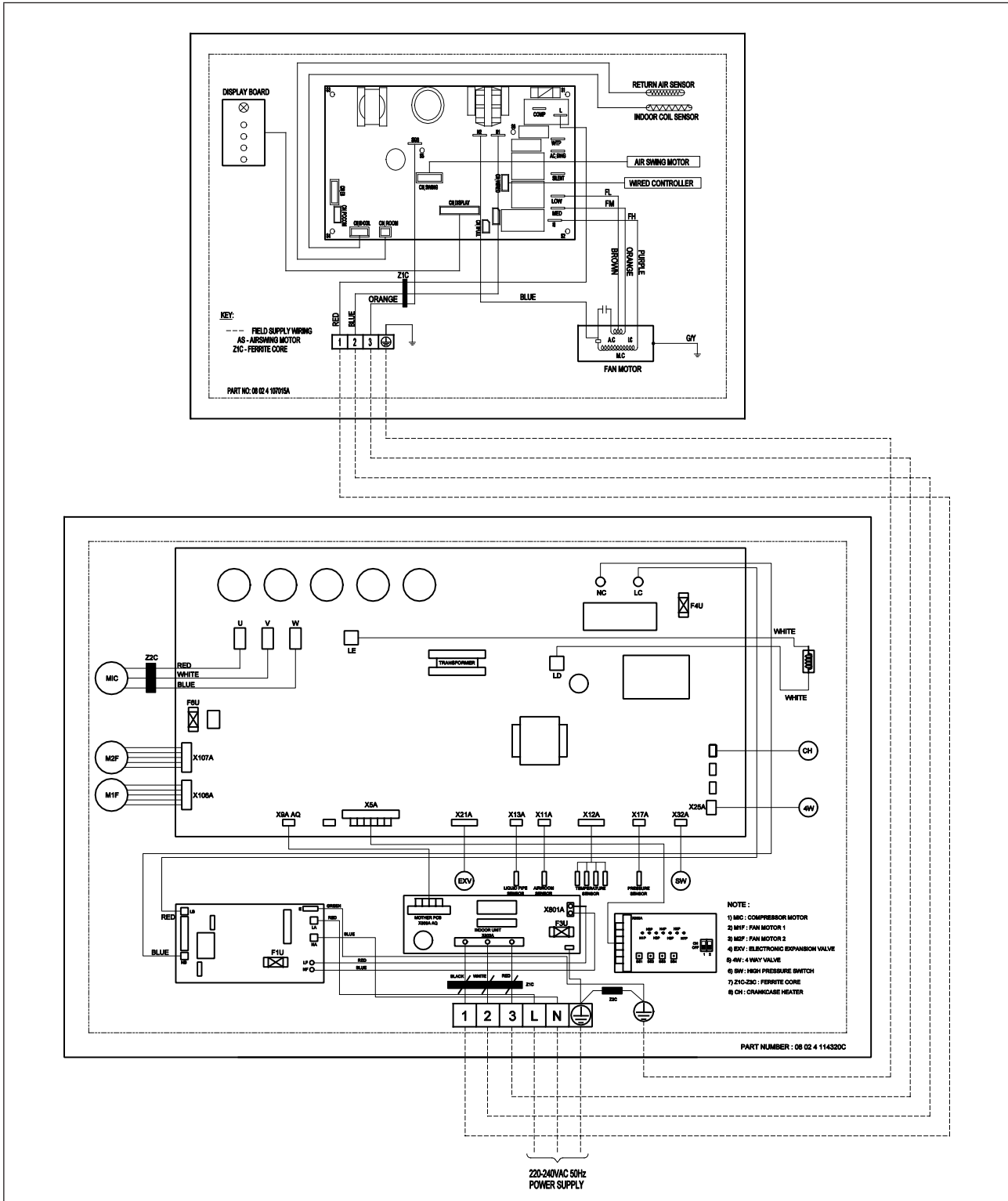

Drawing number: 4109274

Indoor Unit
Model: A5CMY 62CR

Outdoor Unit
Model: A5LCY 60FR

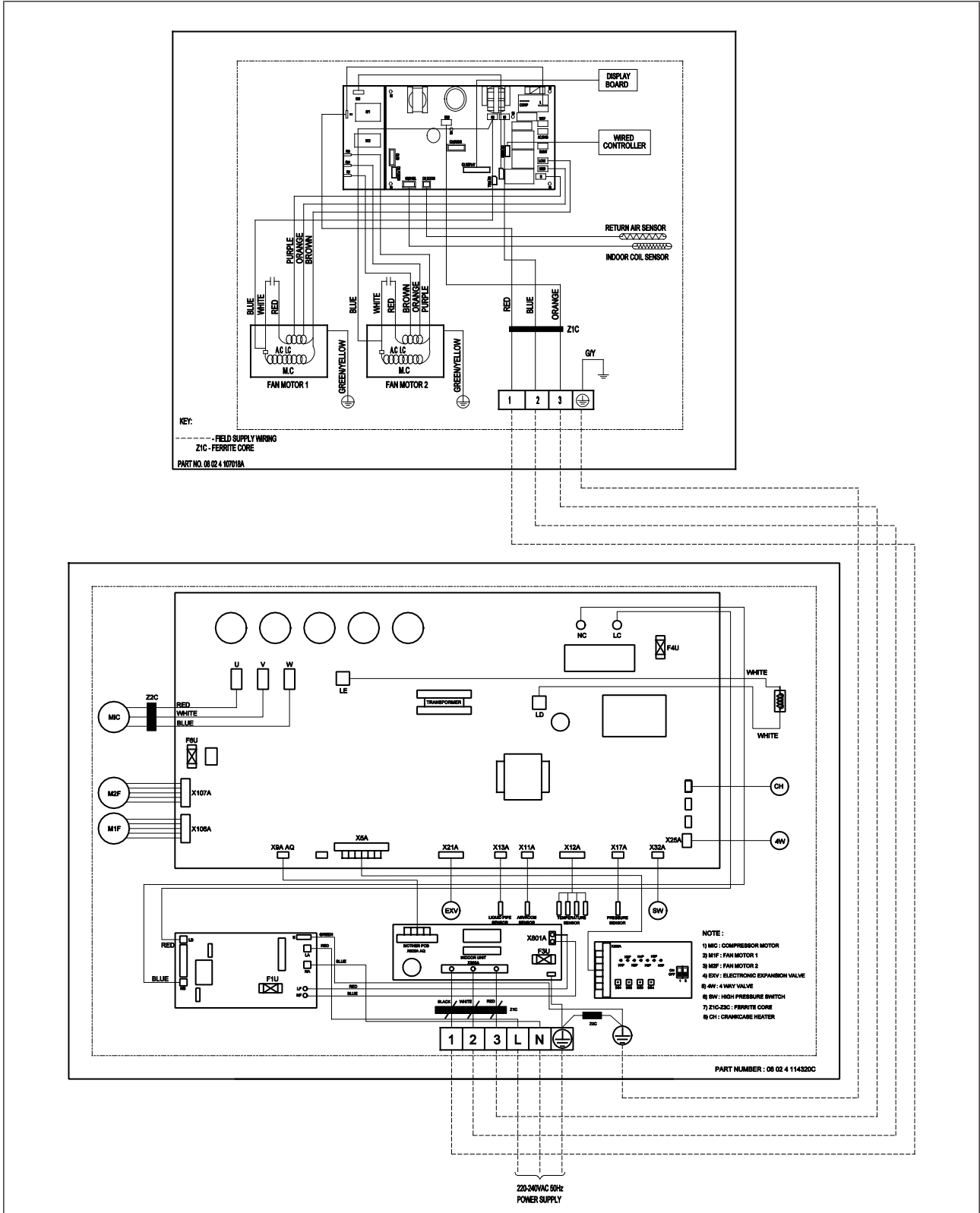

Drawing number: 4109273

Indoor Unit
Model: A5CCY 28CR

Outdoor Unit
Model: A5LCY 28CR

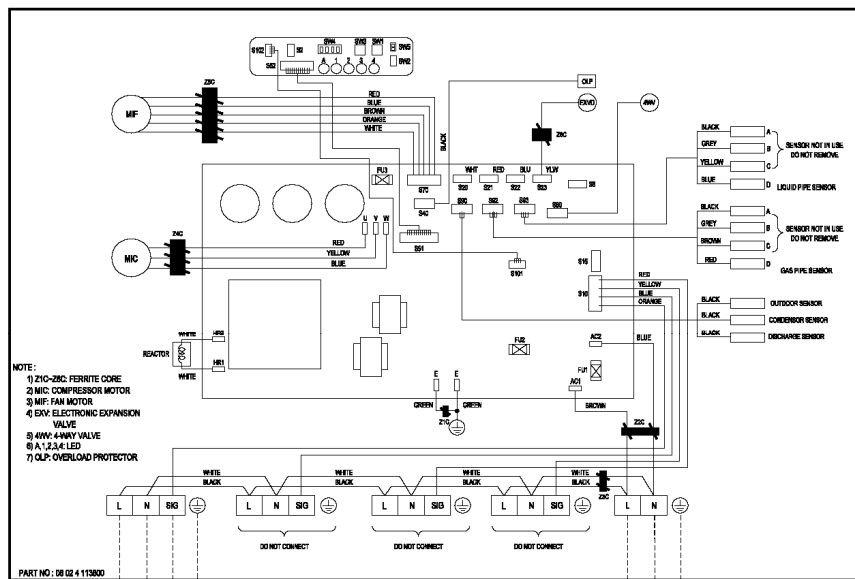
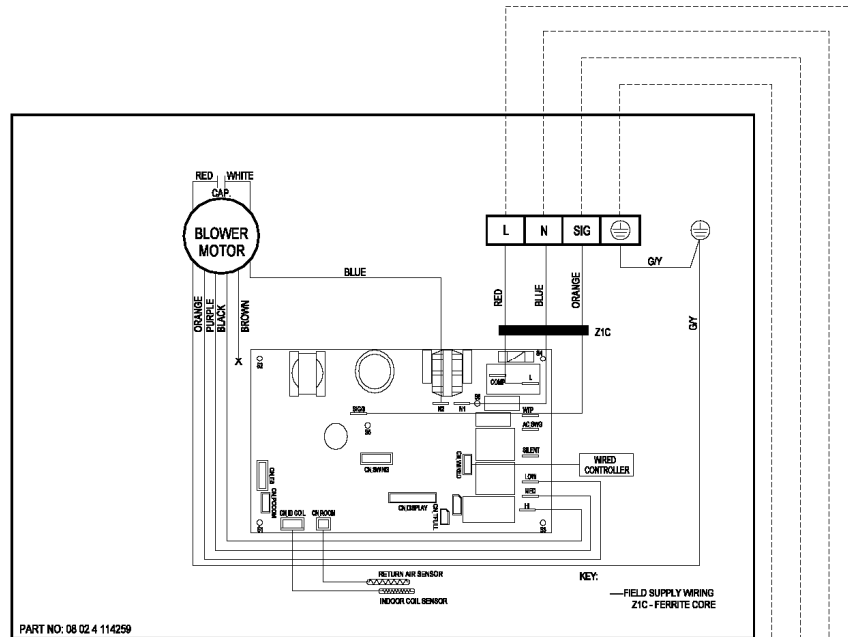

Drawing number: 4114396

Indoor Unit
Model: A5CCY 38/50/60CR

Outdoor Unit
Model: A5LCY 40/50/60FR

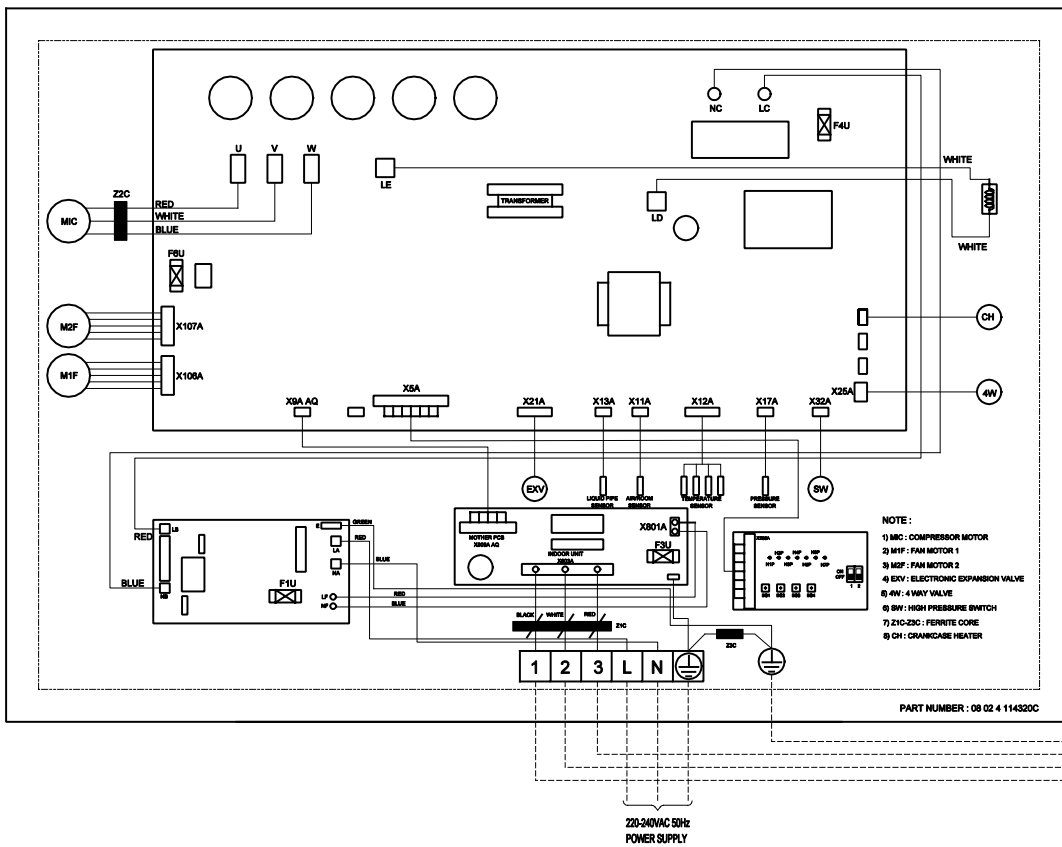
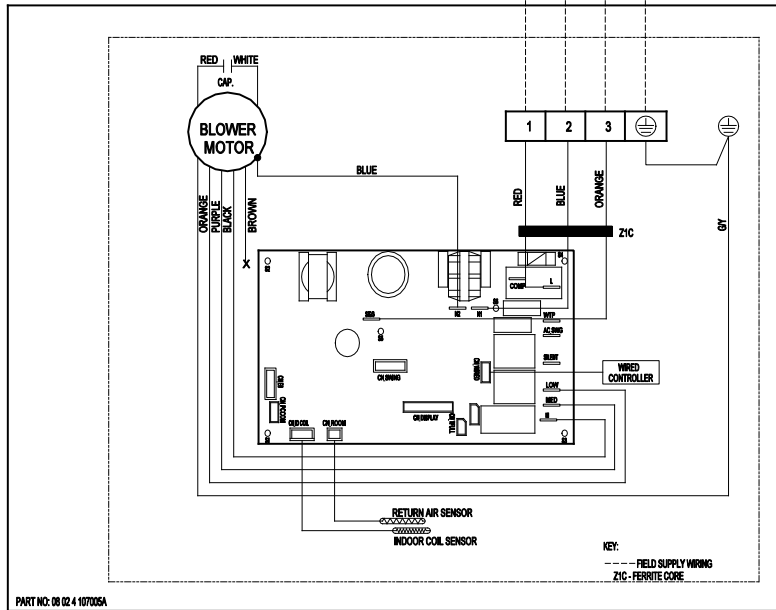

Drawing number: 41097777

Wiring Diagrams (3 Phase)

Indoor Unit
Model: A5CKY 40/50ER

Outdoor Unit
Model: A5LCY 40/50FR

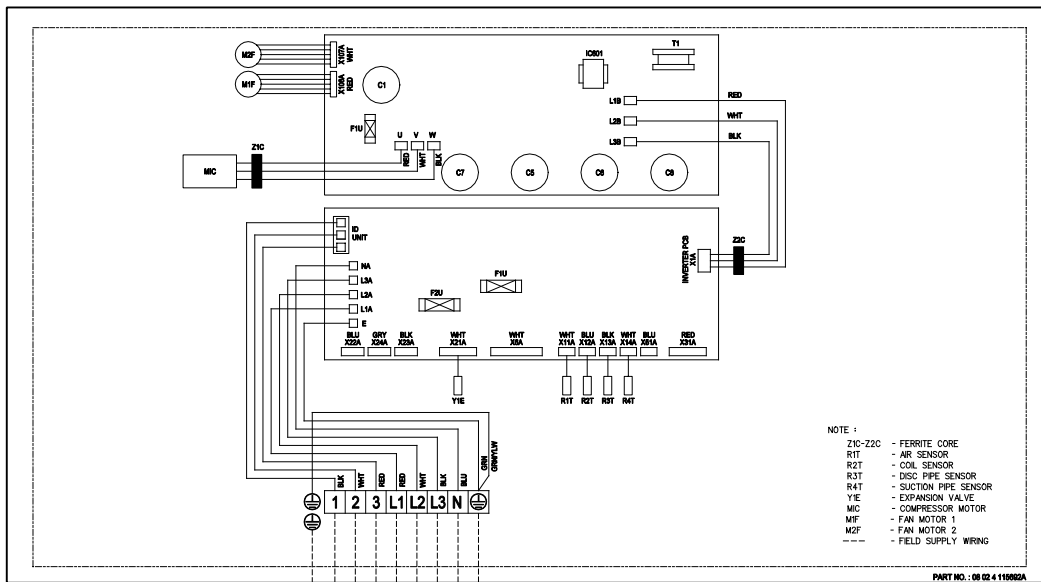
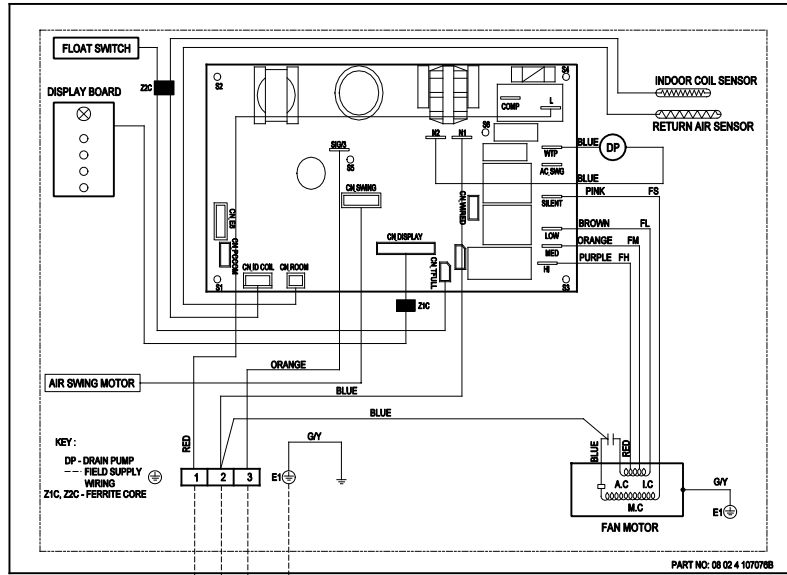

Drawing number: 4116869

Indoor Unit
Model: A5CMY 40/50ER

Outdoor Unit
Model: A5LCY 40/50FR

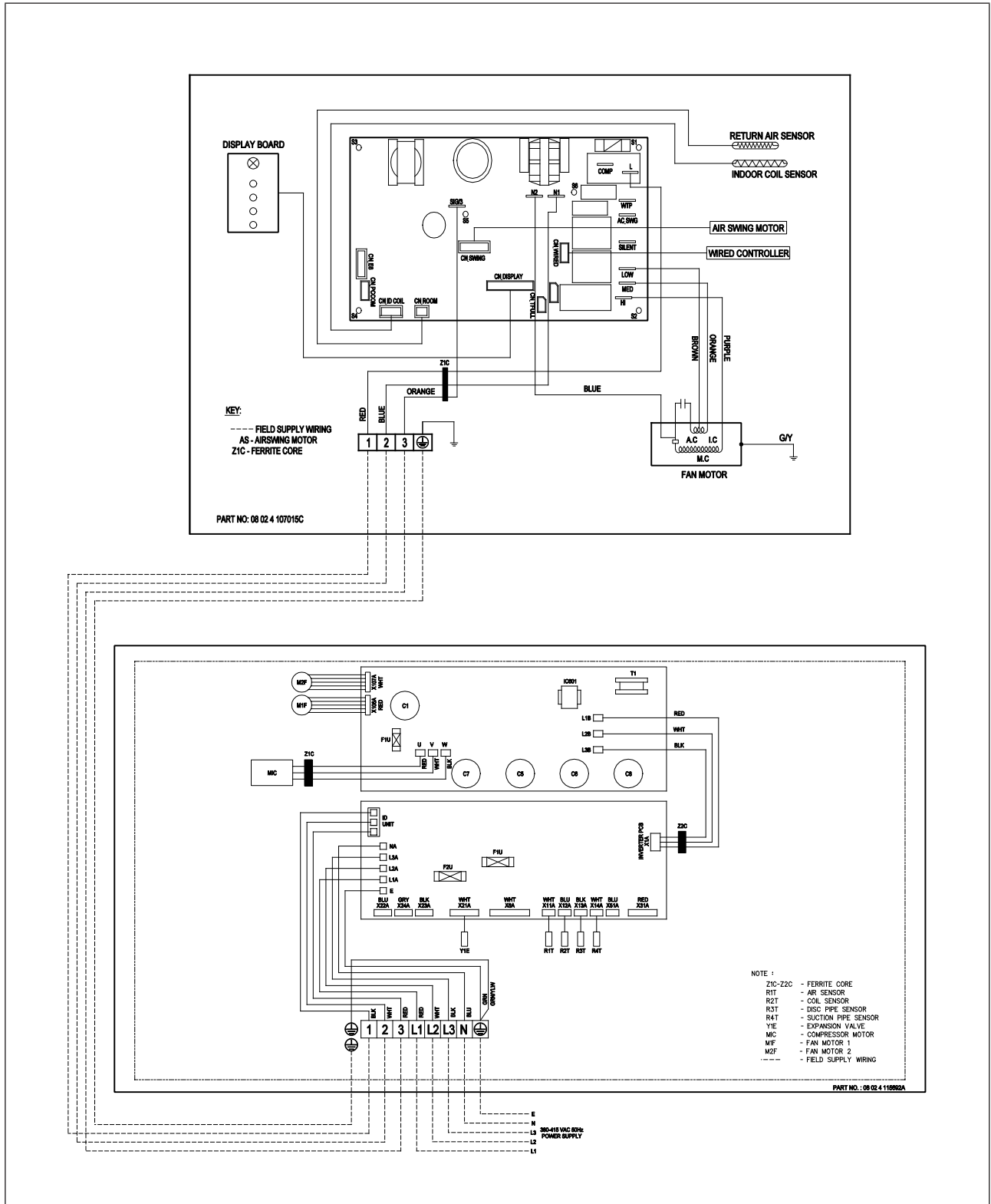

Drawing number: 4116871

Indoor Unit
Model: A5CMY 62CR

Outdoor Unit
Model: A5LCY 60FR

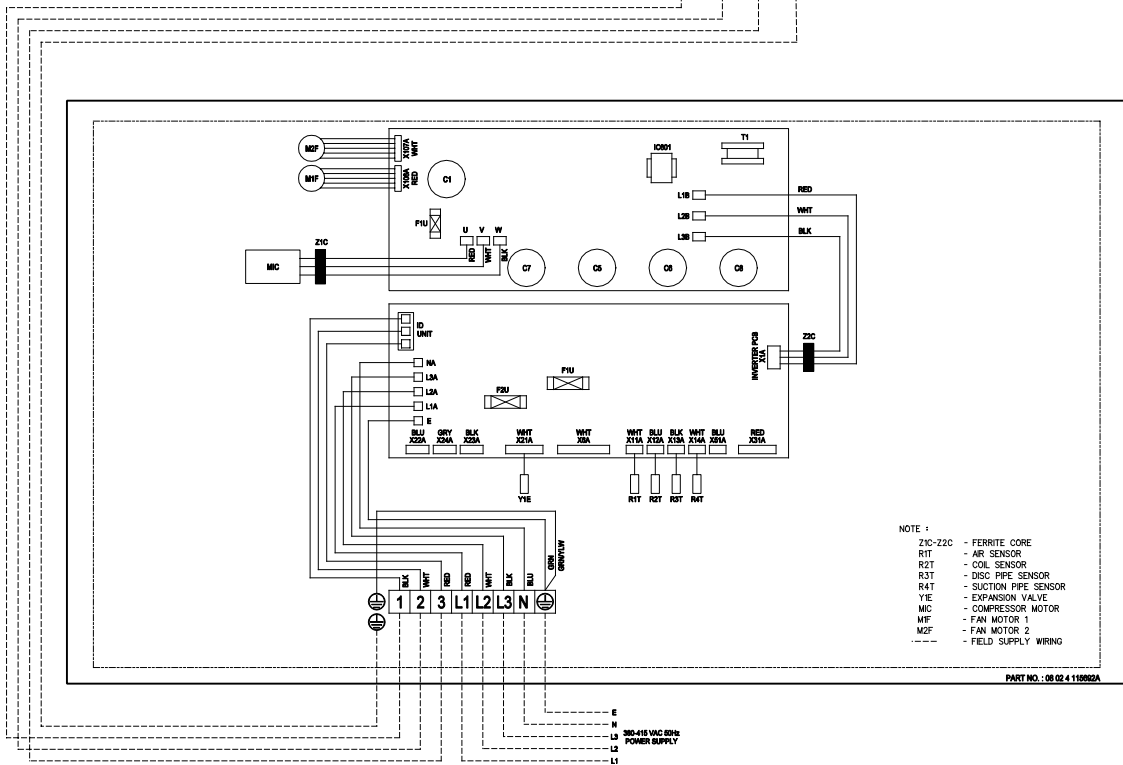
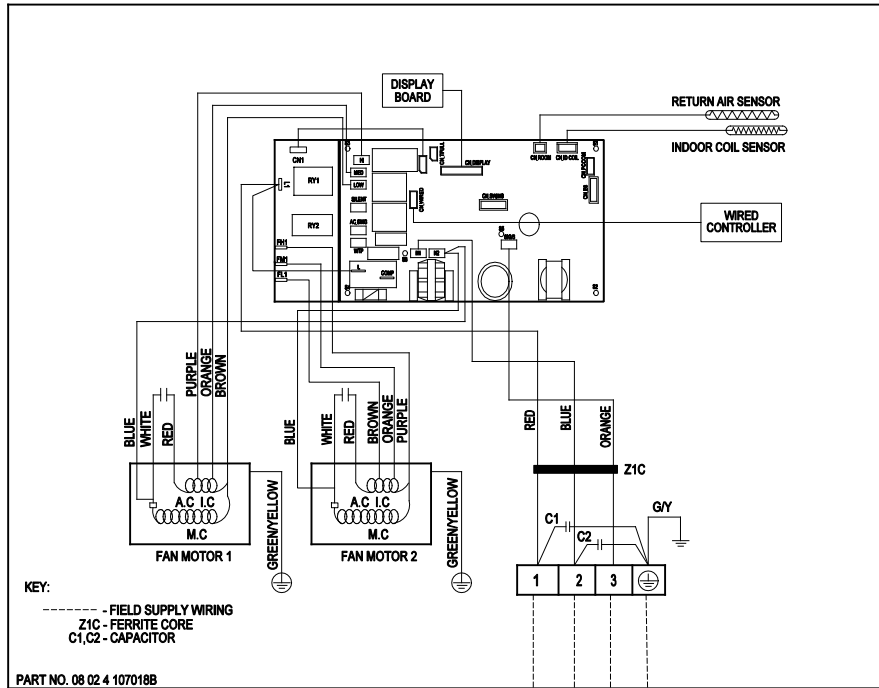

Drawing number: 4116872

Indoor Unit
Model: A5CCY 38/50/60CR

Outdoor Unit
Model: A5LCY 40/50/60FR

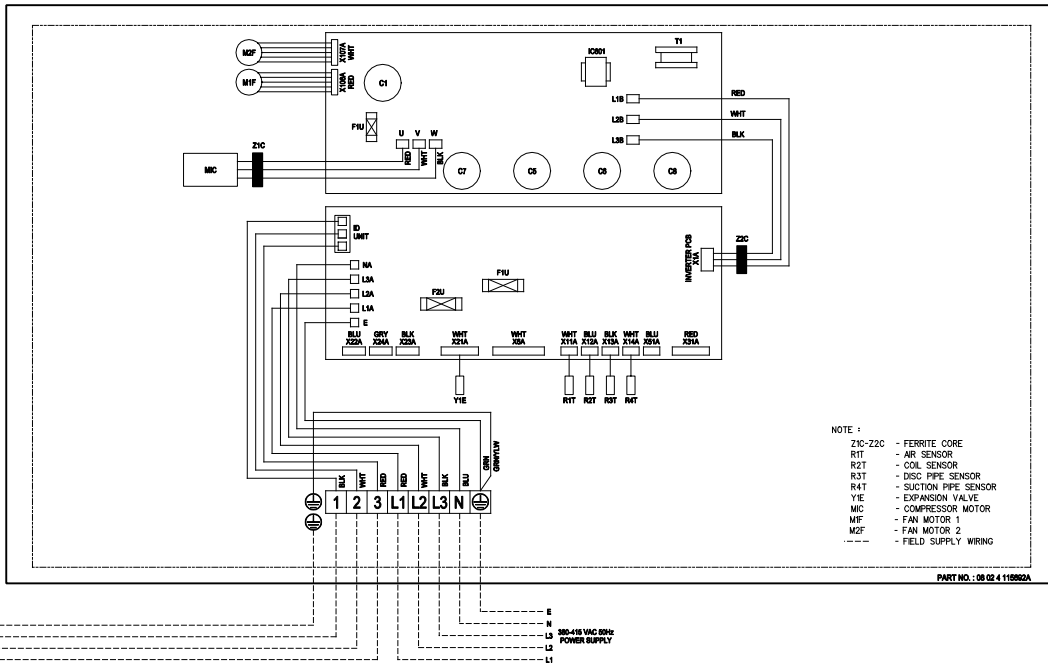
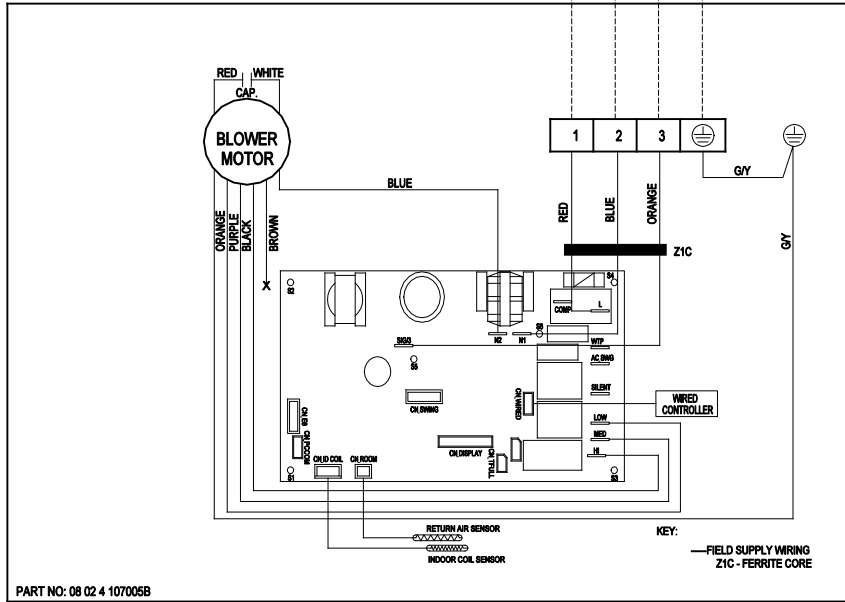

Drawing number: 4116870

Service and Maintenance

Warning

- Disconnect from main supply before servicing the air conditioner.
- The unit is designed to give long life operation with minimum maintenance required. However, it should be regularly checked and the following items should be given due attention.

Components	Maintenance Procedures	Period
Air Filter (Indoor Unit)	<ol style="list-style-type: none"> 1. Remove any dust adhering to the filter by using a vacuum cleaner or wash in lukewarm water (below 40°C) with a neutral cleaning detergent. 2. Rinse the filter well and dry before placing it back onto the unit. 3. Note: Never use gasoline, volatile substances or chemicals to clean the filter. 	At least once every 2 weeks. More frequently if necessary.
Indoor Unit	<ol style="list-style-type: none"> 1. Clean any dirt or dust on the grille or panel by wiping it with a soft cloth soaked in lukewarm water (below 40°C) and a neutral detergent solution. 2. Note: Never use gasoline, volatile substances or chemicals to clean the indoor unit. 	At least once every 2 weeks. More frequently if necessary.
Condense Drain Pan & Pipe	<ol style="list-style-type: none"> 1. Check the cleanliness and clean it if necessary. 2. Check the condensate water flow. 	Every 3 months.
Indoor Fan	Check if there is any abnormal noise.	If necessary.
Indoor / Outdoor Coil	<ol style="list-style-type: none"> 1. Check and remove the dirt between the fins. 2. Check and remove any obstacles which hinder air flow through the indoor or outdoor. 	Every month.
Power Supply	<ol style="list-style-type: none"> 1. Check the running current and voltage for indoor and outdoor unit. 2. Check the electrical wiring and tighten the wire onto the terminal block if necessary. 	Every 2 months. Every year.
Compressor	No maintenance needed if refrigerant circuit remains sealed. However, check for refrigerant leak at joint and fitting.	Every 6 months.

Indoor Models

1. Open the front panel
 - Hold the panel at the recesses on the main unit (2 recesses on right and left sides) and lift it until it stops.
2. Remove the front panel
 - While lifting the front panel further, slide it to the right and pull it to the front side. The left rotating shaft is detached. Slide the right rotating shaft to the left and pull it to the front side to remove it.
3. Attach the front panel
 - Align the right and left rotating shafts of the front panel with the grooves and push them all the way in.
 - Gently close the front panel. (Push both ends and the center on the front panel.)

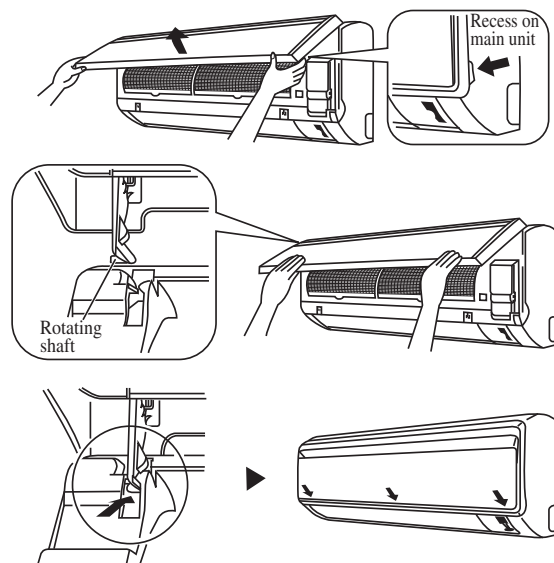

Caution

- Don't touch the metal parts of the indoor unit. It may cause an injury.
- When removing or attaching the front panel, use a robust and stable stool and watch your steps carefully.
- When removing or attaching the front panel, support the panel securely with hand to prevent from it falling.
- For cleansing, do not use hot water above 40°C, benzene, gasoline, thinner, nor other volatile oils, polishing compound, scrubbing brushes, nor other hand stuff.
- After cleaning, make sure that the front panel is securely fixed.

Pre Start Up Maintenance (After Extended Shutdown)

- Inspect thoroughly and clean indoor and outdoor units.
- Clean or replace air filters.
- Clean condensates drain line.
- Clean clogged indoor and outdoor coils.
- Check fan imbalance before operation.
- Tighten all wiring connections and panels.
- Check for refrigerant leakage.

Outdoor Models

The design of the A5LC outdoor series allows servicing to be carried out easily. The removal of the top, front and side panels makes almost every part accessible.

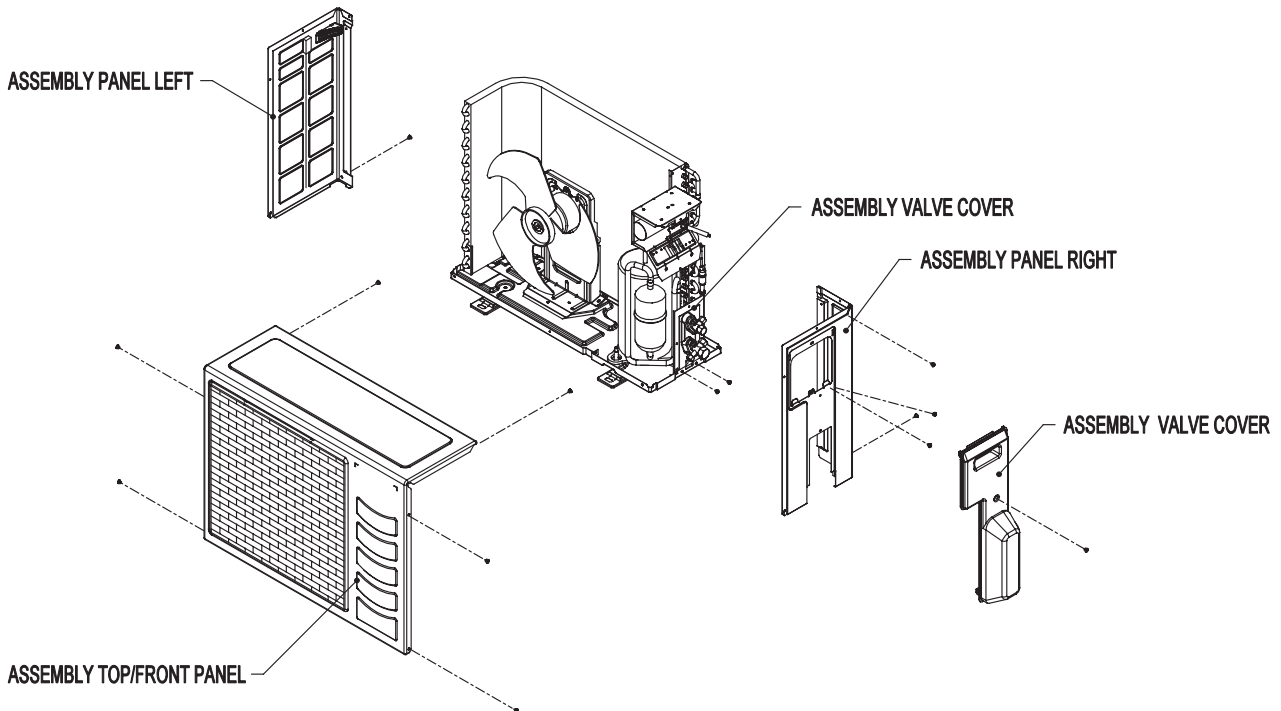



Under normal circumstances, these outdoor units only require a check and cleaning of air intake coil surface once every 3 months. However, if a unit is installed in areas subjected to much oil mist and dust, the coils must be regularly cleaned by qualified Air Conditioner Service Technicians to ensure sufficient heat exchange and proper operation. Otherwise, the systems life span may be shortened.

Caution

- Do not charge OXYGEN, ACETYLENE OR OTHER FLAMMABLE and poisonous gases into the unit when performing a leakage test or an airtight test. These gases could cause severe explosion and damage if exposed to high temperature and pressure.
- It is recommended that only nitrogen or refrigerant be charged when performing the leakage or airtight test.

Troubleshooting

Indicator Light

 SLEEP (RED)	 COOL/HEAT (GREEN/RED)	 TIMER (YELLOW)	Operation / Faulty Indication
	○ Green		• Cooling mode
	○ Red		• Heating mode
	○ Red		• Auto mode in heating operation
	○ Green		• Auto mode in cooling operation
	○	○	• Time Off (when unit is on)
		○	• Time On (when unit is off)
○	○		• Sleep mode on
	○ Green		• Fan mode on
	○ Green		• Dry Mode on
	● Red		• Defrost operation
	● Green		• Error indication

○ ON

● BLINKING

Error Code

Error Codes	Error Description	Action
0	Normal	No action.
U0	Insufficient gas	1. Check sensor connection.
		2. Check stop valve.
		3. Check for gas leak.
		4. Check the EXV.
		5. Check H8.
U2	DC voltage out of range	1. Check the supply voltage.
		2. Check the outdoor fan by rotating with hand.
		3. Restart the system.
		4. Check power supply waveform.
U4	Communication error	1. Check the indoor unit - outdoor unit connection wires.
		2. Check the voltage of the signal terminal.
		3. Check the indoor fan by rotating with hand.
		4. Check the power supply waveform.
U7	Signal transmission error (on outdoor unit PCB)	1. Restart the system.
		2. Replace outdoor PCB.
		3. Long term monitor on external factor.
UA	Installation error	1. Check the indoor and outdoor unit model name.
		2. Check the part code on the indoor and outdoor PCB.
UF	Communication Error (indoor and outdoor) piping and wiring	1. Check the wiring and piping between indoor and outdoor units.
		2. Check refrigerant level.
		3. Check refrigerant line on blockage.
UH	Anti-freeze function in other room	1. Check which indoor having error A5.
		2. Check the supply voltage.
		3. Check the indoor and outdoor model name.
A1	Indoor PCB error	1. Check connector connection.
		2. Replace indoor PCB.
A3	Water pump error	1. Check for short circuit.
		2. Check connection on drain pump.
		3. Restart the system.
		4. Check the drain water level.
		5. Check float switch connection.
A5	Antifreeze	1. Check the air passage.
		2. Check the intake air filter.
		3. Check dust accumulation on indoor coil.
		4. Check wiring and piping.
		5. Check the EXV.
		6. Check indoor coil sensor resistance value.
		7. Check refrigerant level.
		8. Check room sensor resistance value.

Error Codes	Error Description	Action
A6	Indoor fan motor abnormal	1. Check the indoor fan by rotating with hand.
		2. Replace indoor fan motor if not rotating smoothly.
		3. Check fan motor voltage.
		4. Replace indoor PCB if not at the rated voltage.
		5. Check fan capacitor's conductivity (AC Motor).
		6. Replace fan capacitor if there's conductivity.
C4	Indoor heat exchanger thermistor short/open	1. Check the connector connection.
C9	Indoor room thermistor short/open	2. Check the sensor resistance value.
E1	Outdoor PCB error	1. Restart the system.
		2. Replace outdoor PCB.
		3. Check to see that the unit is grounded.
		4. Check power supply waveform.
E3	High pressure protection	1. Check installation conditions.
		2. Check stop valve.
		3. Check HPS connection.
		4. Check pressure level by pressure gauge.
		5. Wait for 10 minutes then restart the system.
		6. Check if H3 is displayed.
E4	Low pressure protection	1. Check stop valve.
		2. Check low pressure sensor connection.
		3. Check low side pressure and voltage.
		4. Check outdoor coil sensor connection.
		5. Check sensor resistance value.
		6. Check refrigerant level.
E5	Compressor motor lock/overload	1. Check connection on discharge pipe sensor.
		2. Check discharge pipe sensor resistance value.
		3. Check the EXV.
		4. Check the refrigerant line on blockage or shortage.
E6	Compressor lock/start-up error	1. Check with inverter checker.
		2. Check the EXV.
E7	Outdoor DC fan motor lock	1. Check the fan motor connection.
		2. Check if foreign matters exist around or in the fan.
E8	Ac input over current	1. Measure the input current.
		2. Check the main circuit electrolytic capacitor.
		3. Check with inverter checker.
		4. Check discharge pressure.
		5. Check the installation condition.

Error Codes	Error Description	Action
E9	EXV error	1. Restart the system.
		2. Check the EXV connection.
		3. Check EXV coil resistance.
		4. Check sensors resistance value.
EA	4-way valve error	1. Check 4WV coil connection.
		2. Check the continuity of the 4WV coil and harness.
		3. Check the 4WV switching output.
		4. Check sensor connection.
		5. Check sensor resistance value.
		6. Check the refrigerant line on blockage or shortage.
F3	Discharge pipe overheat	1. Check the discharge pipe sensor.
		2. Check the EXV.
		3. Check the refrigerant line on blockage or shortage.
F6	Heat exchanger overheat	1. Check the installation space.
		2. Check the outdoor fan.
		3. Check the EXV.
		4. Check the coil sensor.
H0	Compressor sensor system abnormality	1. Check the reactor connection.
		2. Check the compressor connection.
		3. Measure the resistance value between the reactor terminals.
		4. Measure the resistance value between the compressor terminals.
H3	High pressure switch error	1. Check pressure sensor connection.
		2. Check HPS continuity.
H6	Position sensor abnormality	1. Check for short circuit.
		2. Check the electrolytic capacitor voltage.
		3. Check compressor harness wire.
		4. Check with inverter checker.
H8	AC current sensor error	1. Restart the system.
		2. Check capacitor voltage.
		3. Measure the rectifier input voltage.
		4. Check compressor harness wire.
		5. Check with inverter checker.
H9	Outdoor air thermistor short / open	1. Check the sensor connection.
		2. Check the sensor resistance value.
J1	Pressure sensor error	1. Check pressure sensor connection.
		2. Check pressure and voltage level.
J3	Compressor discharge pipe thermistor short / open / misplaced	1. Check the sensor connection.
		2. Check the sensor resistance value.
		3. Check indoor coil sensor resistance value.

Error Codes	Error Description	Action
J5	Suction pipe thermistor short / open	Same as H9.
J6	Outdoor heat exchanger	
J7	Subcooling heat exchanger thermistor short/open	
J8	Liquid pipe thermistor short/open	
J9	Gas pipe thermistor abnormality	
LC	Communication Error (control PCB and inverter PCB)	1. Check fan motor connection. 2. Check if LED blinking normally at outdoor PCB.
L1	Outdoor PCB error	1. Check the range of power supply.
		2. Check connection between compressor and PCB.
		3. Check fan motor resistance.
		4. Check the power supply waveform.
L3	Electrical box temperature rise	1. Restart the system.
		2. Check sensor resistance value.
		3. Check heat sink temperature and conditions.
		4. Check outdoor fan.
		5. Check the installation condition.
L4	Heat sink overheat	1. Restart the system.
		2. Check the silicon grease condition on heat sink.
		3. Check sensor resistance value.
		4. Check heat sink temperature and conditions.
		5. Check outdoor fan.
		6. Check the installation condition.
L5	IPM error / IGBT error	1. Check stop valve.
		2. Check with inverter checker.
		3. Check the power transistor and supply voltage.
		5. Check the compressor phase.
		6. Check the discharge pressure.
		7. Check the installation condition.
		L8
L9	Stall prevention	1. Check installation conditions.
		2. Check stop valve.
		3. Check difference between high and low pressure side.
		4. Check continuity on the power transistor.
		5. Check the output voltage.
P1	Open phase or voltage unbalance	1. Check LED on outdoor PCB.
		2. Check open phase of power supply voltage.
		3. Check voltage balance between phases.
P4	Heat sink thermistor short / open	Same as H9.
PJ	Capacity setting error	1. Check the connection between capacitor and outdoor PCB.

Exploded View and Part List

Indoor Unit
 Model: APLCKY-ER

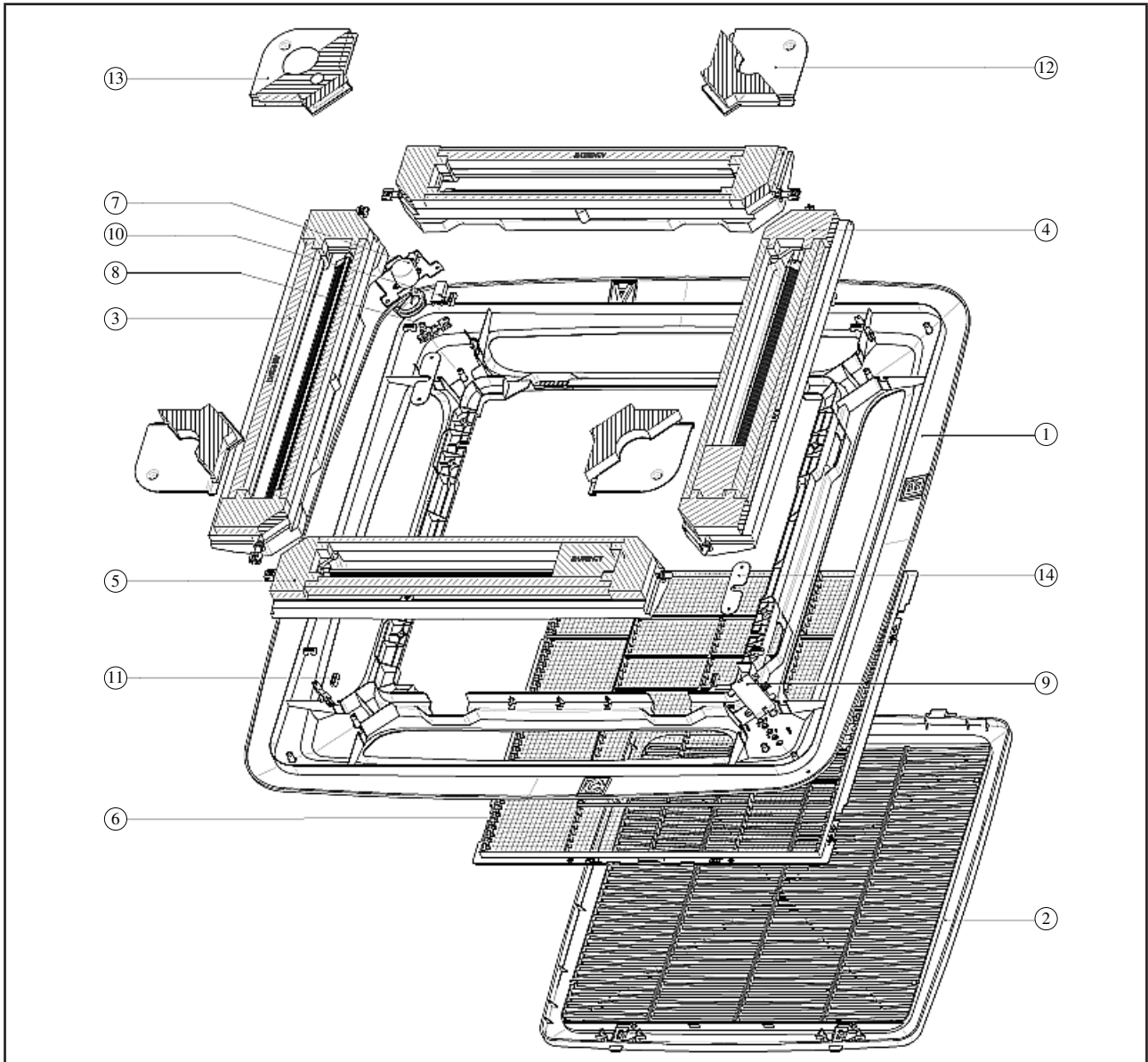

70024109309

No	Description
1	Front, Frame
2	Assy., Intake Grille
3	Assy., Air Discharge Main
4	Assy., Air Discharge Main Right
5	Assy., Air Discharge Main Left
6	Air Filter, CK-A/AR
7	Assy., Air Swing Motor

No	Description
8	Crank Connector
9	Assy., LED
10	Wire, Guide
11	Cover, Cross Connector
12	Assy., Cover Corner A
13	Assy., Cover Corner B
14	Mounting Plate

Model: A5CKY28ER

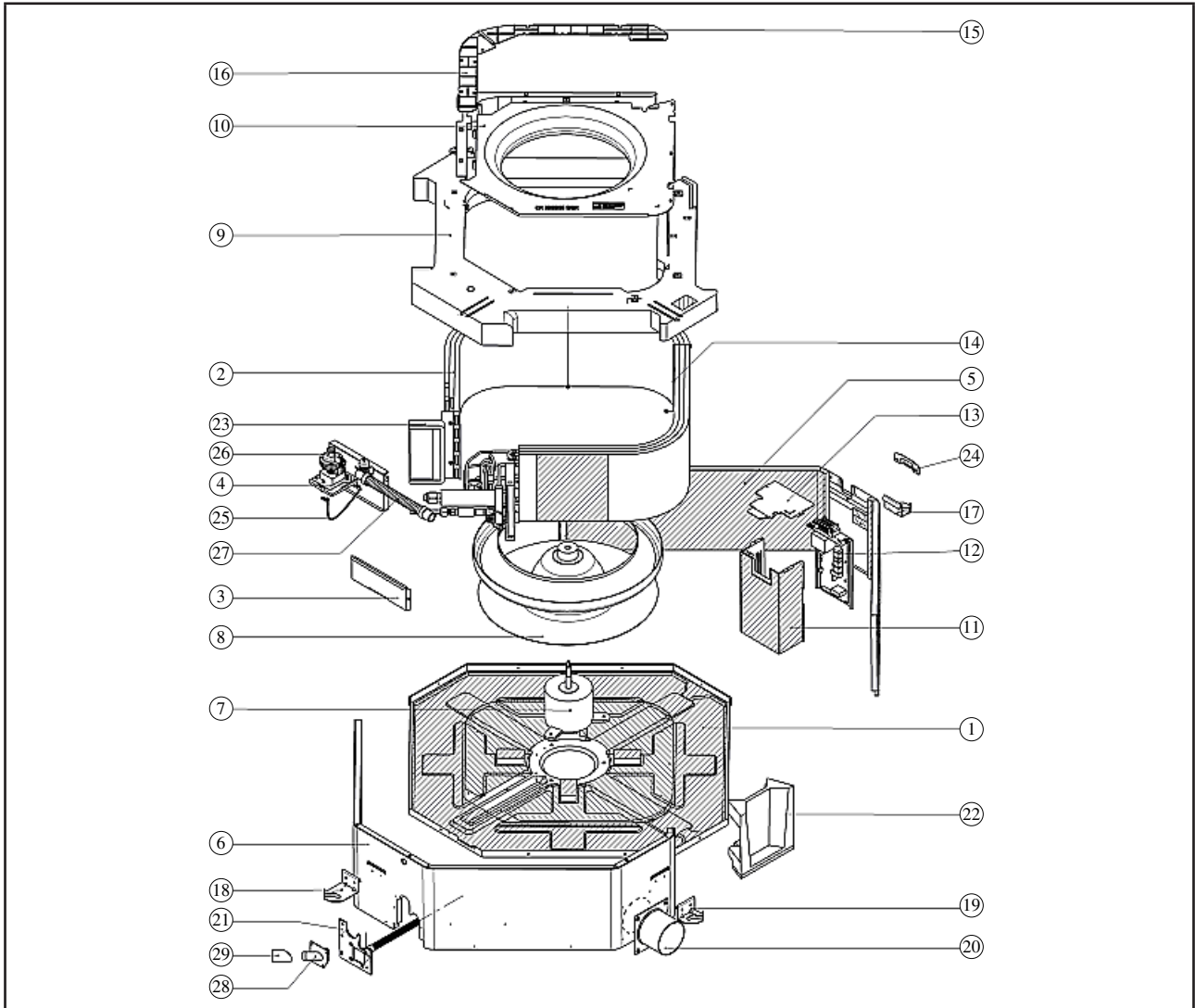

70024108768

No	Description
1	Assy. Base Pan
2	Assy. Coil
3	Assy. Coil Bracket
4	Assy. Drain Pump Mounting
5	Assy. Panel Side Back
6	Assy. Side Panel Front
7	Assy. Motor & Rubber
8	Blower, Turbo Fan DIA462 X 171.5 3P085496-1
9	Assy. Drain Pan
10	Assy. Fan Cover
11	Assy. Cover Control Box
12	Assy. Control Box
13	Assy. Cover Terminal
14	Support, Coil

No	Description
15	Cover, Wire A
16	Cover, Wire B
17	Bracket, Hanger A
18	Bracket, Hanger B
19	Bracket, Hanger C
20	Fresh Air Adaptor
21	Assembly, Valve Plate
22	Assy. Air Guide
23	Assy. Partition Holder
24	Cover, Wire
25	Switch Water Level 1A - CK Drain Pump
26	Pump, Water PC-04226-OYOB YCK
27	Hose, Drain PE 18.3 X 0.5 X 315.0
28	Connector, Drain
29	Ins., Drain Connector

Model: A5CKY40ER

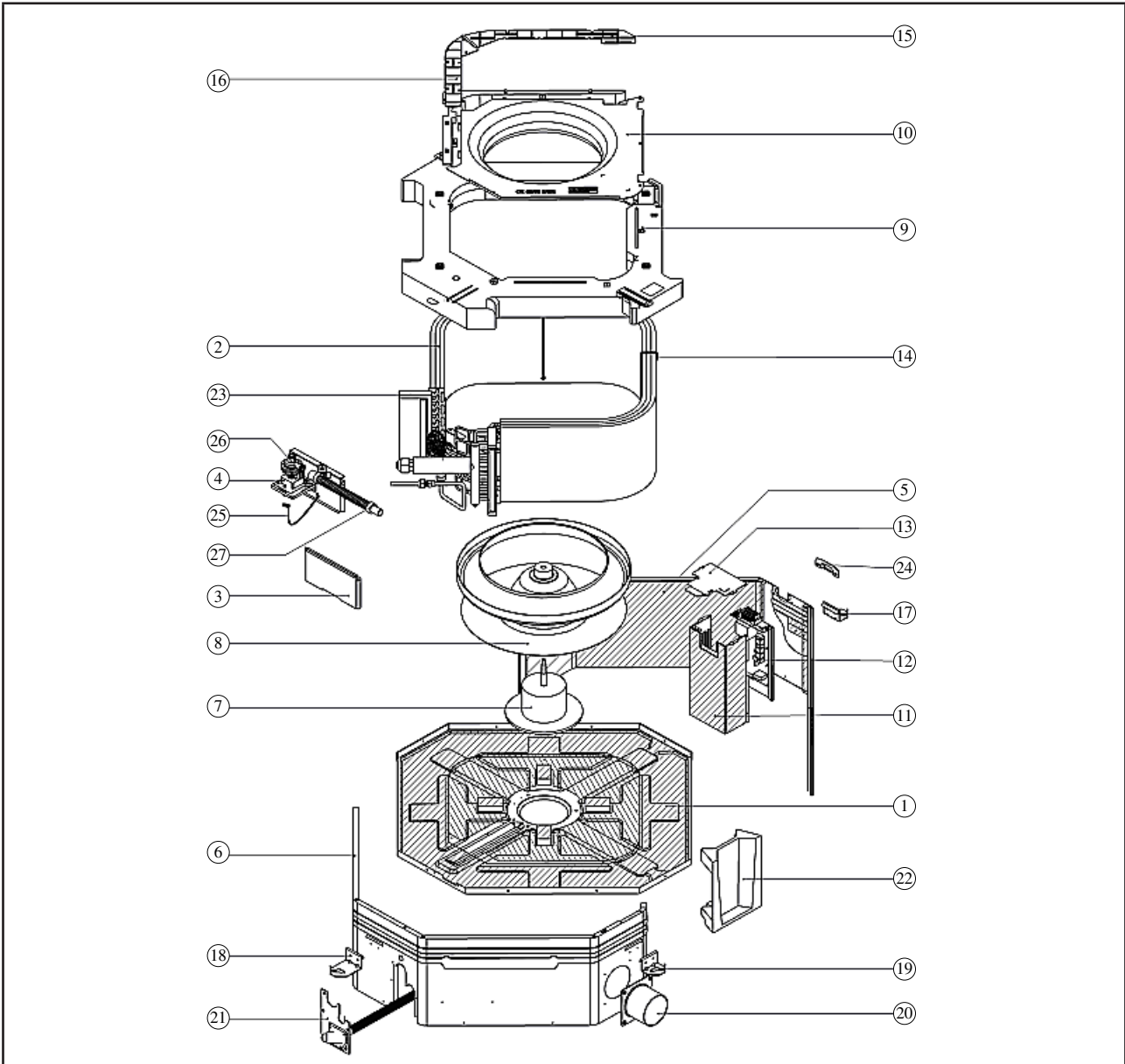

70024108769

No	Description
1	Assy. Base Pan
2	Assy. Coil
3	Assy. Coil Bracket
4	Assy. Drain Pump Support Bracket
5	Assy. Panel Side Back
6	Assy. Side Panel Front
7	Assy. Motor & Rubber
8	Blower, Turbo Fan DIA462 X 171.5 3P085496-1
9	Assy. Drain Pan
10	Assy. Fan Cover
11	Assy. Cover Control Box
12	Assy. Control Box
13	Assy. Cover Terminal
14	Support, Coil

No	Description
15	Cover, Wire A
16	Cover, Wire B
17	Bracket, Hanger A
18	Bracket, Hanger B
19	Bracket, Hanger C
20	Fresh Air Adaptor
21	Assembly, Valve Plate
22	Assy. Air Guide
23	Assy. Partition Holder
24	Cover, Wire
25	Switch Water Level 1A - CK Drain Pump
26	Pump, Water PC-04226-OYOB YCK
27	Hose, Drain PE 18.3 X 0.5 X 315.0

Model: A5CKY50ER

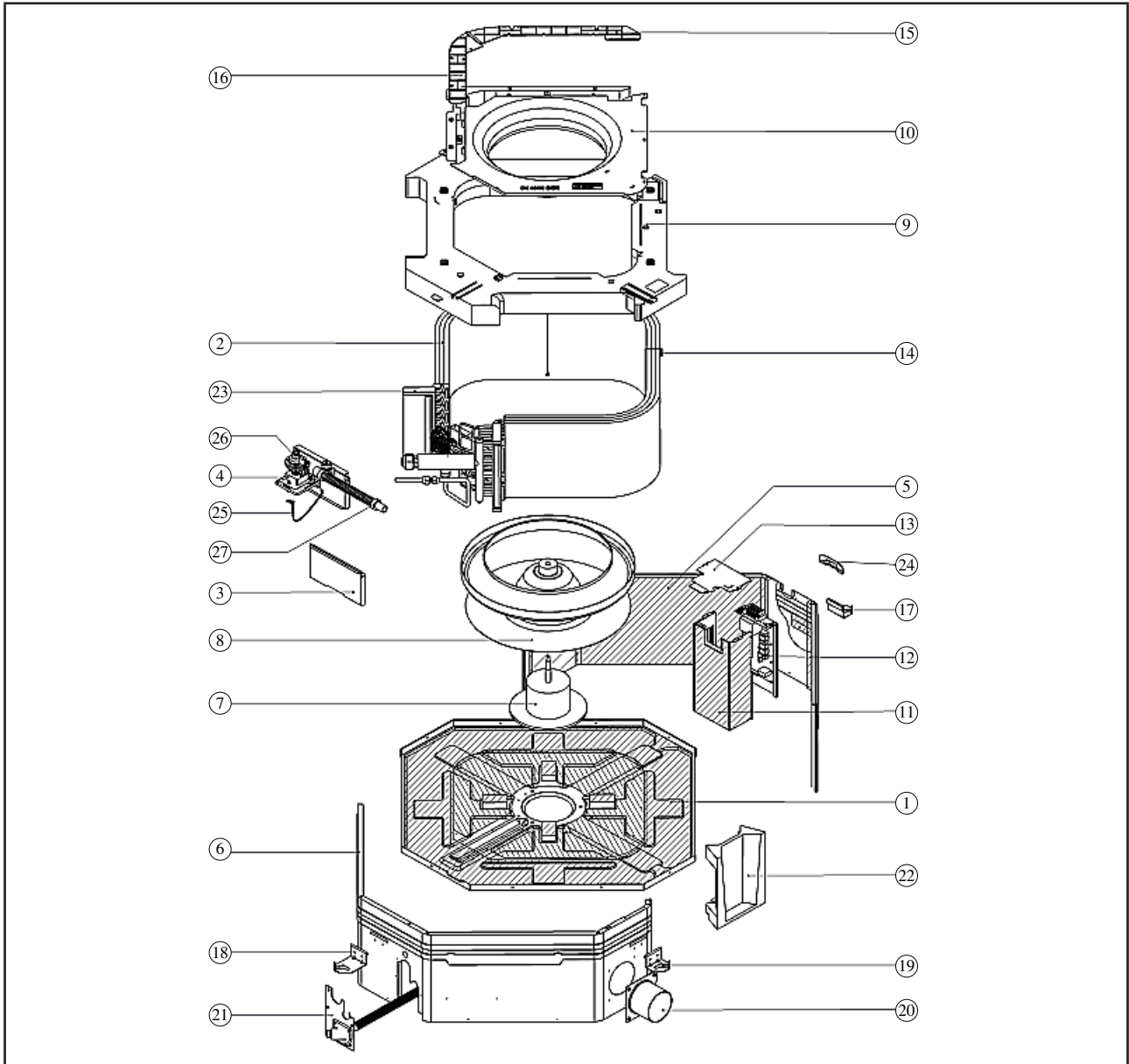

70024108770

No	Description
1	Assy. Base Pan
2	Assy. Coil
3	Assy. Coil Bracket
4	Assy. Drain Pump Mounting
5	Assy. Panel Side Back
6	Assy. Side Panel Front
7	Assy. Motor & Rubber
8	Blower, Turbo Fan DIA462 X 171.5 3P085496-1
9	Assy. Drain Pan
10	Assy. Fan Cover
11	Assy. Cover Control Box
12	Assy. Control Box
13	Assy. Cover Terminal
14	Support, Coil

No	Description
15	Cover, Wire A
16	Cover, Wire B
17	Bracket, Hanger A
18	Bracket, Hanger B
19	Bracket, Hanger C
20	Fresh Air Adaptor
21	Assembly, Valve Plate
22	Assy. Air Guide
23	Assy. Partition Holder
24	Cover, Wire
25	Switch Water Level 1A - CK Drain Pump
26	Pump, Water PC-04226-OYOB YCK
27	Hose, Drain PE 18.3 X 0.5 X 315.0

Model: A5CCY28CR

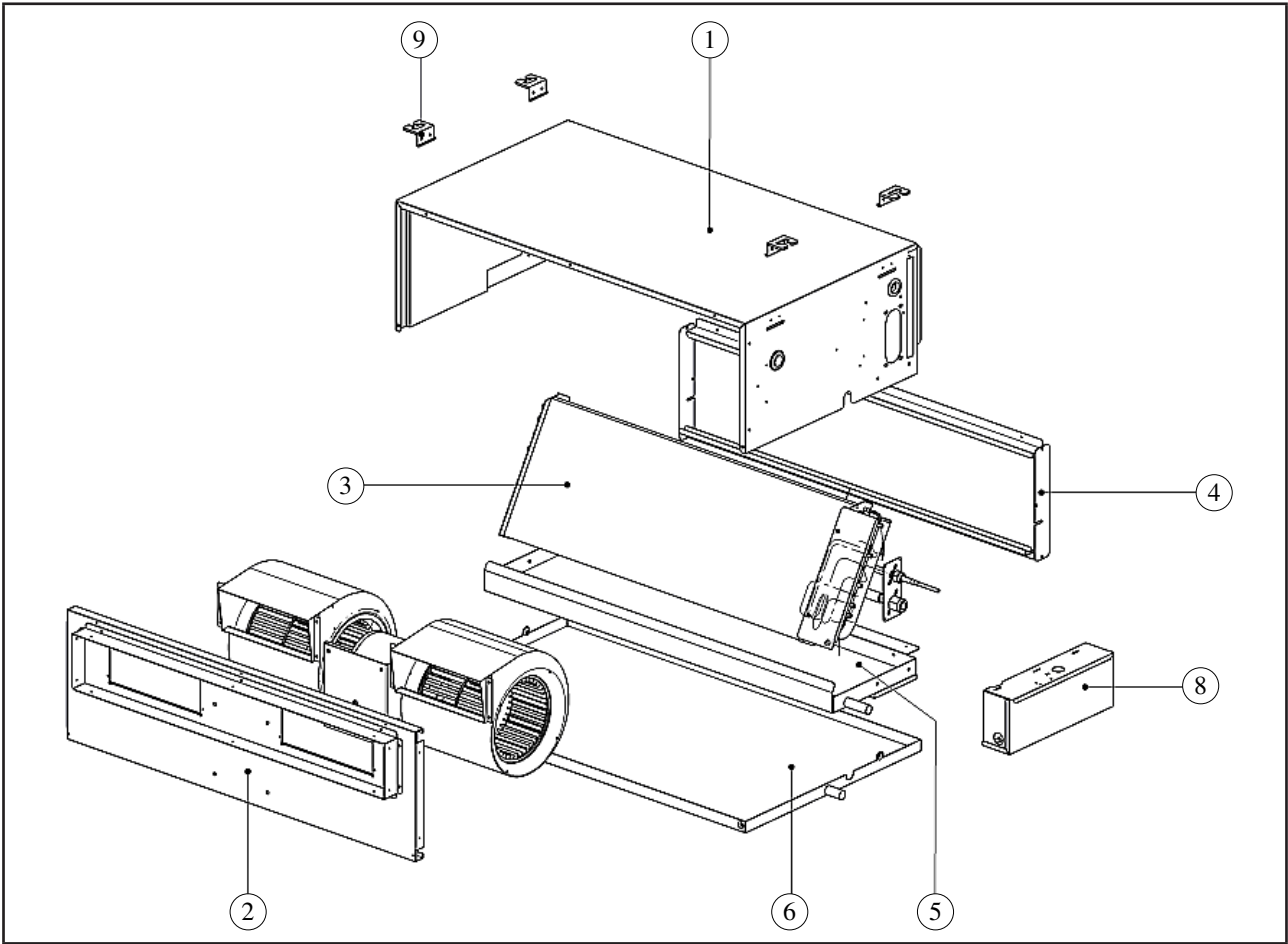

70024108760

No	Description
1	Panel Top
2	Assy., Panel Blower
3	Assy., Coil Main
4	Rail, Filter Cover
5	Assy., Drain Pan Small

No	Description
6	Assy., Drain Pan Big
7	Filter, Saranet
8	Assy., Control Box
9	Hanger

Model: A5CCY38CR

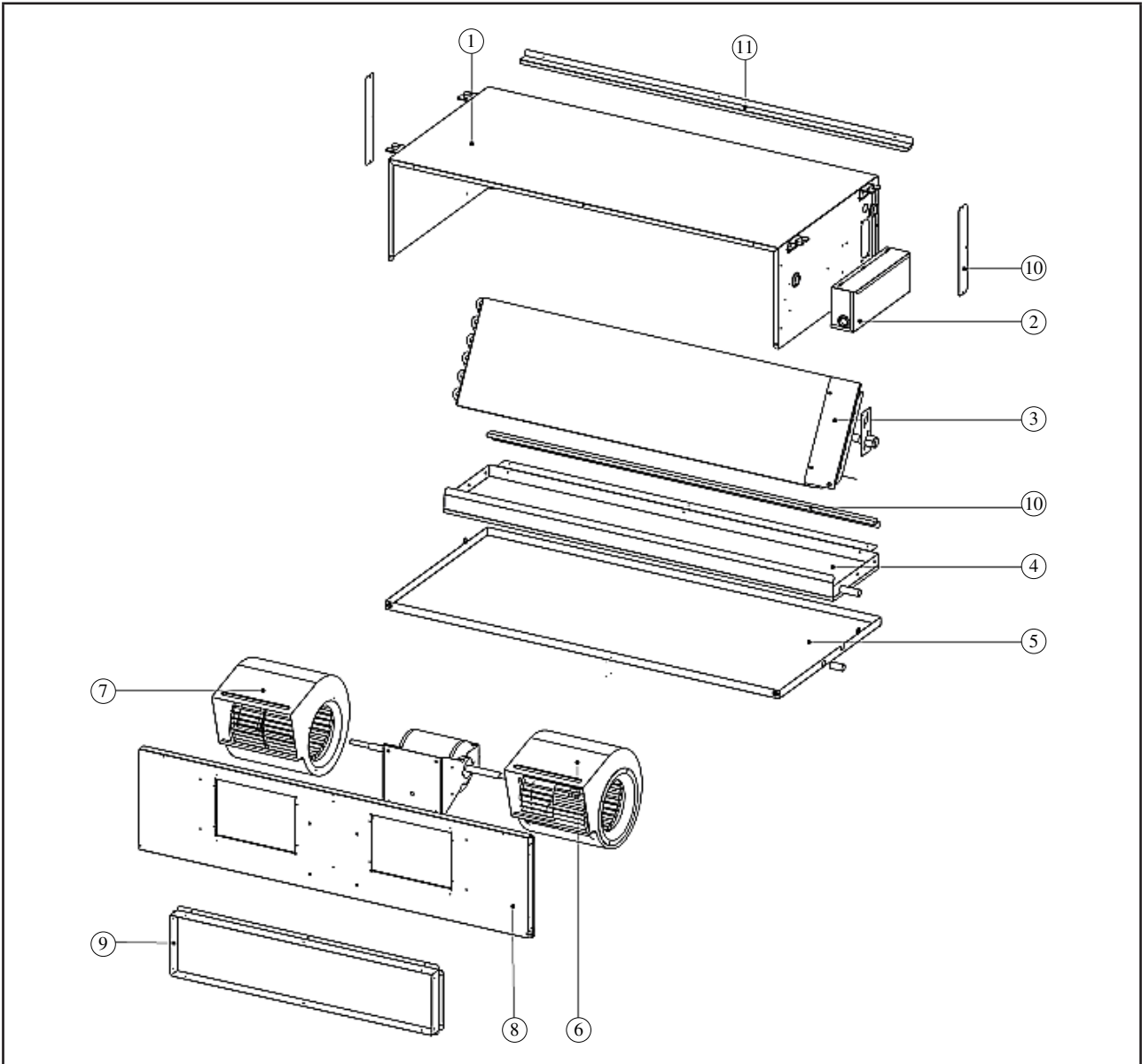

70024108761

No	Description
1	Panel Top
2	Assy., Control Box
3	Assy., Coil
4	Assy., Drain Pan Small
5	Assy., Drain Pan Big

No	Description
6	Assy., Blower Housing Left
7	Assy., Blower Housing Right
8	Panel, Blower
9	Flange, Blower Top/Bottom
10	Cover, Rail Filter
11	Rail, Filter

Model: A5CCY50CR

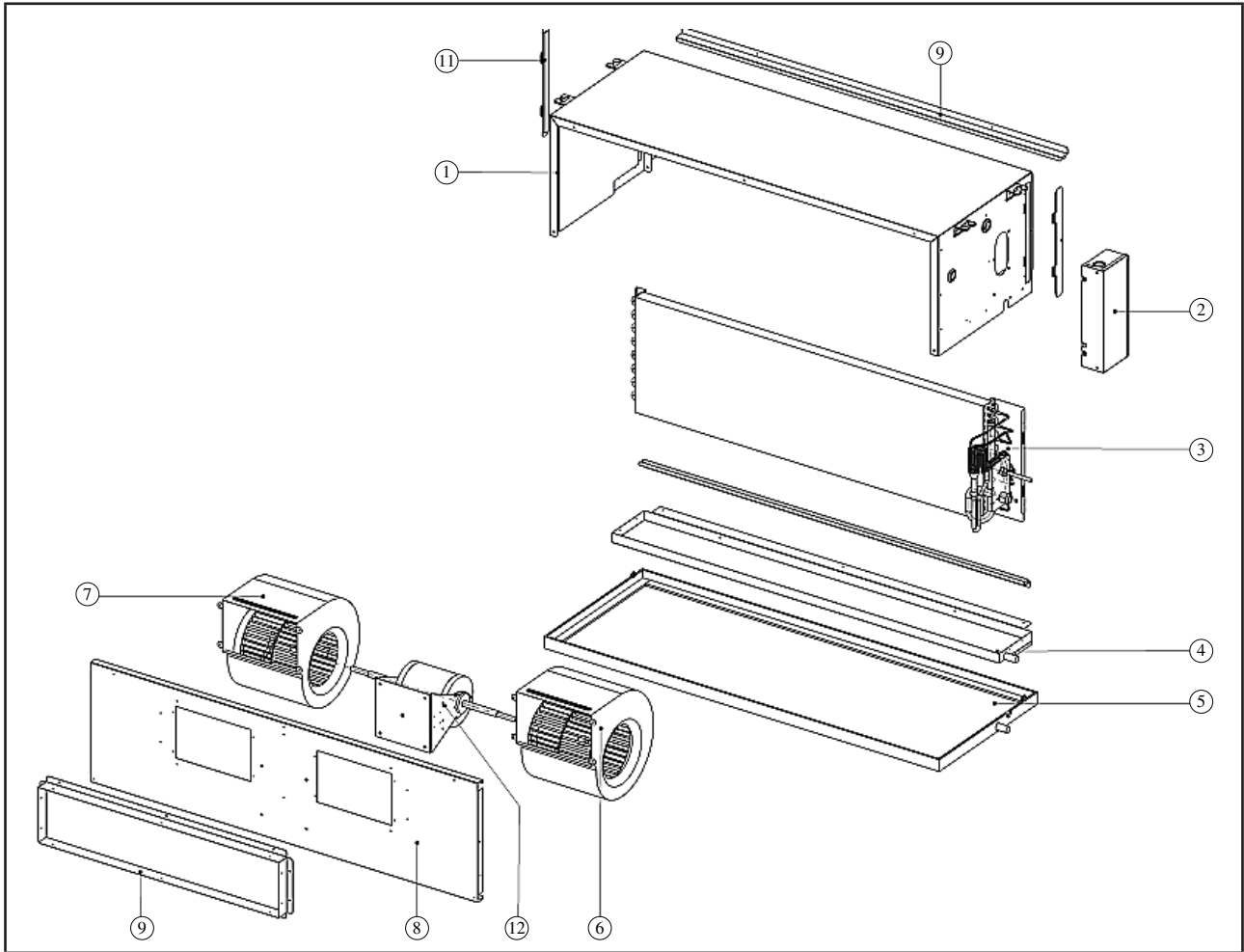

70024108762

No	Description
1	Assy., Panel Top
2	Assy., Control Box
3	Assy., Coil
4	Assy., Drain Pan Small
5	Assy., Drain Pan Big
6	Assy., Blower Wheel - L 320mm

No	Description
7	Assy., Blower Wheel - R 320mm
8	Panel, Blower
9	Flange, Blower
10	Rail, Filter
11	Assy., Cover Filter L/R
12	Assy., Motor

Model: A5CCY60CR

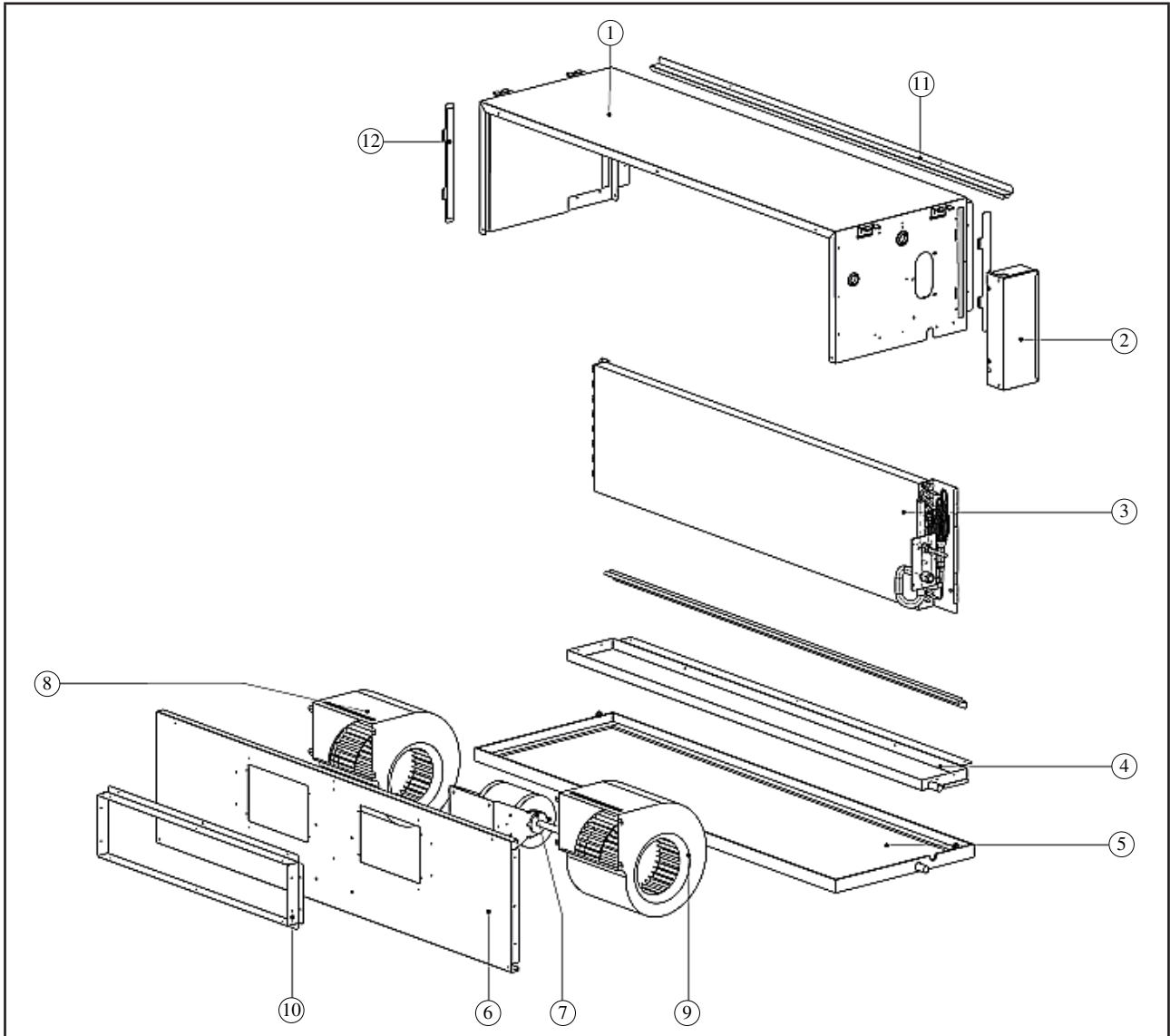

70024108763

No	Description
1	Assy., Panel Top
2	Assy., Control Box
3	Assy., Coil
4	Assy., Drain Pan Small
5	Assy., Drain Pan Big
6	Panel, Blower

No	Description
7	Assy., Motor
8	Assy., Blower Wheel - R 320mm
9	Assy., Blower Wheel - L 320mm
10	Flange, Blower
11	Rail, Filter
12	Assy., Cover Filter L/R

Model: A5CMY28ER

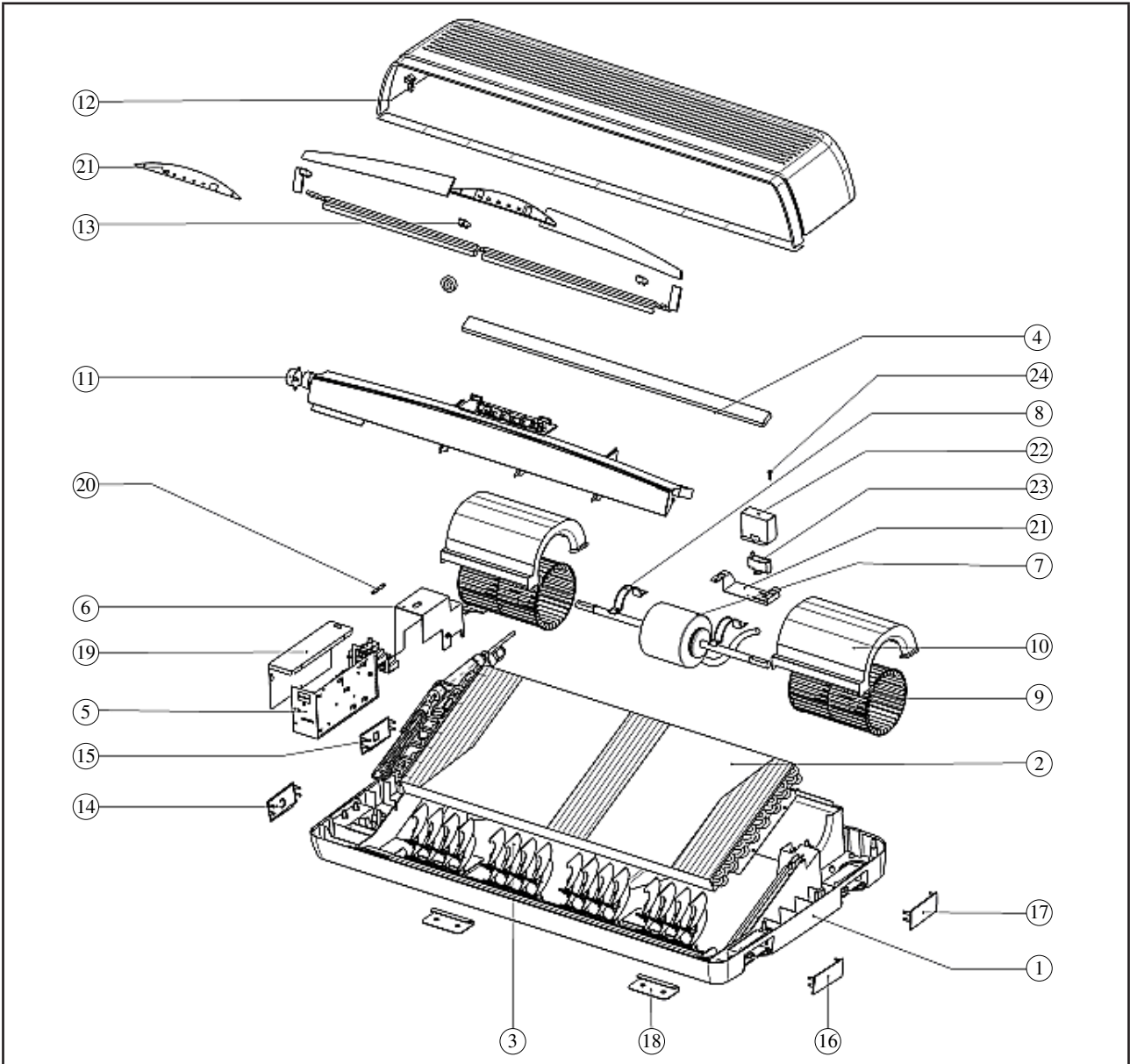

70024108764

No	Description
1	Assy. Top Panel
2	Assy. Coil Indoor
3	Assy. Vane
4	Assy. Ins. Drain Pan
5	Assy. Control Box
6	Cover, Terminal Box
7	Motor, MCE28E-501 4P 70W 1PH
8	Bracket, Motor
9	Blower
10	Housing, Blower Top
11	Motor, Air Swing
12	Assy., Bottom Panel

No	Description
13	Cap Screw
14	Cover, Hanger Left 1
15	Cover, Hanger Left 2
16	Cover, Hanger Right 1
17	Cover, Hanger Right 2
18	Mounting Bracket
19	Cover, Control Box
20	Clamp, Wire
21	Bracket, Capacitor
22	Cover, Capacitor
23	Capacitor
24	Screw, PH Binding Head 8x3/4" A

Model: A5CMY40ER

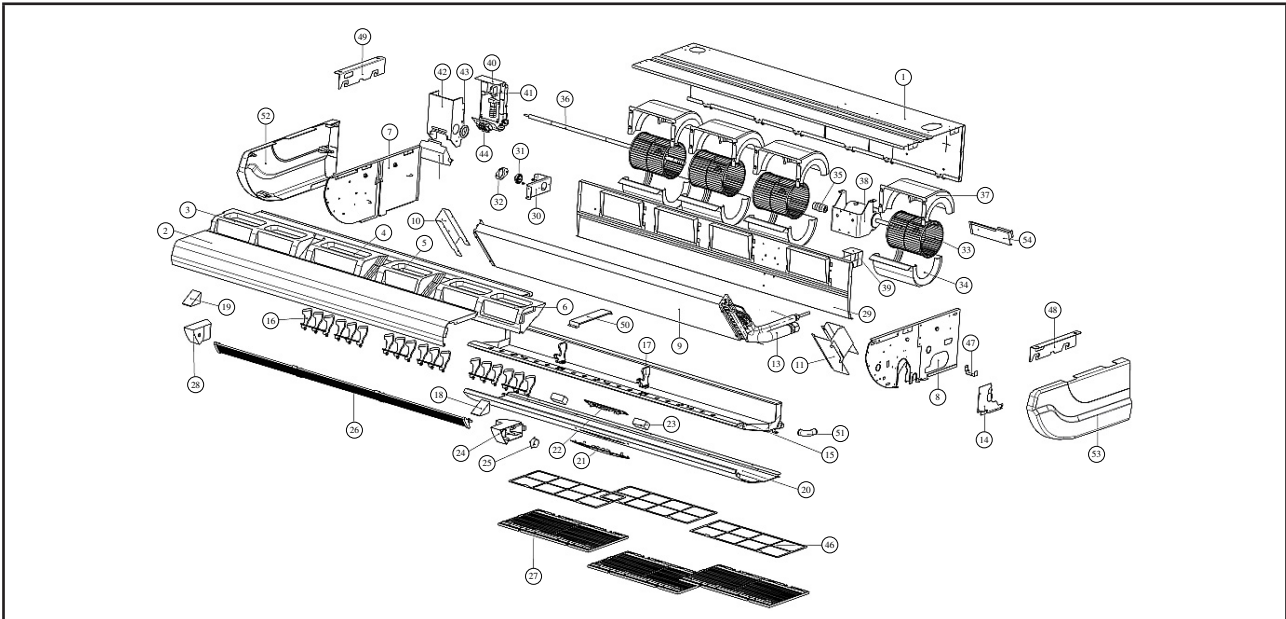

70024108765

No	Description
1	Assy. Panel Top/Back
2	Panel Front
3	Foam, Discharge Left
4	Foam Discharge Center A
5	Foam Discharge Center B
6	Foam, Discharge Right
7	Assy., Bracket Left
8	Assy., Bracket Right
9	Assy., Coil Expanded
10	Support, Coil Right
11	Support, Coil Left
12	Assy., Liquid Tube
13	Assy., Gas Tube
14	Assy., Valve Plate
15	Assy., Drain Pan
16	Assy., Vane
17	Support, Louver
18	Ins., Discharge Right
19	Ins., Discharge Left
20	Panel, Bottom
21	Panel, LED
22	Assy., Mounting LED
23	Ins., Stopper Bottom Panel
24	Cover, Louver Right
25	Motor, MP35EA HIGASHI FUJI/LEILI
26	Assy., Louver
27	Assy., Intake Grille A (467mm)

No	Description
28	Cover Louver Left
29	Assy., Panel Fan Deck
30	Bracket, Bearing
31	Bearing, Assy. CE (4PAD4079C)
32	Bracket, Bearing Fixing
33	Blower Wheel - 2PA51505
34	2PA54302D Fan Housing -1-FHYJ140
35	Coupling, Rubber DIA. 12MM (R3763650G)
36	Shaft, Diameter 15-L829 (3PA54347E)
37	2PA54303D Fan Housing -1-FHYJ140
38	Motor, CE40E (Y5S413D21) 118W BOM
39	Cover, Capacitor
40	Assy., Metal Control Box
41	Control Module, 5CEY40E/ER EC/AP C201AMVBA0A
42	Assy., Cover Control Box
43	Bush, Rubber
44	Terminal Block, T3020A-1-4P-C1.0 20A
45	Cover, Control Box
46	Filter, A (457.0)
47	Bracket, Drain Pipe
48	Bracket, Hanger Right
49	Bracket, Hanger Left
50	Support, Fan Deck
51	Drain Hose, Flexible
52	Panel, Left
53	Panel, Right
54	Assy., Cover Connector

Model: A5CMY50ER

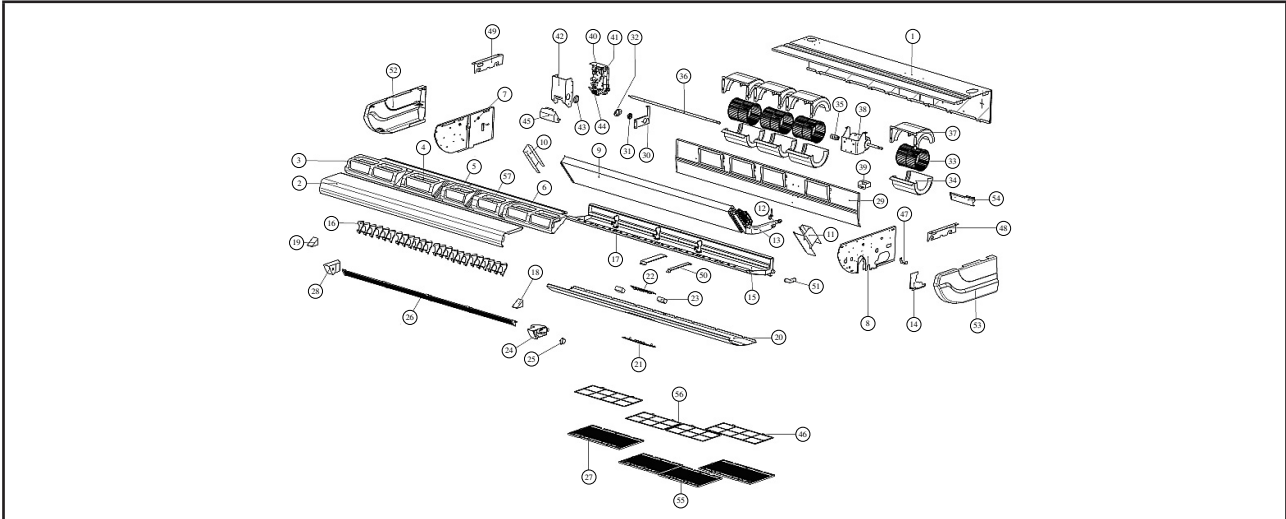

70024108766

No	Description
1	Assy. Panel Top/Back
2	Panel Front
3	Foam, Discharge Left
4	Foam Discharge Center A
5	Foam Discharge Center B
6	Foam, Discharge Right
7	Assy., Bracket Left
8	Assy., Bracket Right
9	Assy., Coil Expanded
10	Support, Coil Right
11	Support, Coil Left
12	Assy., Liquid Tube
13	Assy., Gas Tube
14	Assy., Valve Plate
15	Assy., Drain Pan
16	Assy., Vane
17	Support, Louver
18	Ins., Discharge Right
19	Ins., Discharge Left
20	Panel, Bottom
21	Panel, LED
22	Assy., Mounting LED
23	Ins., Stopper Bottom Panel
24	Cover, Louver Right
25	Motor, STCE50E-117MNM
26	Assy., Louver
27	Assy., Intake Grille A (467mm)
28	Cover Louver Left
29	Assy., Panel Fan Deck

No	Description
30	Bracket, Bearing
31	Bearing, Assy. CE (4PAD4079C)
32	Bracket, Bearing Fixing
33	Blower Wheel - 2PA51505
34	2PA54302D Fan Housing -1-FHYJ140
35	Coupling, Rubber DIA. 14MM (R3763650G)
36	Shaft, Diameter 15-L829 (3PA54347E)
37	2PA54303D Fan Housing -1-FHYJ140
38	Motor, CE50E 4P 149W 1PH
39	Cover, Capacitor
40	Assy., Metal Control Box
41	CTRL MODULE,5CEY50E/ER EC/AP C201AMVBA0A
42	Assy., Cover Control Box
43	Bush, Rubber
44	Terminal Block, T3020A-1-4P-C1.0 20A
45	Cover, Control Box
46	Filter, A (457.0)
47	Bracket, Drain Pipe
48	Bracket, Hanger Right
49	Bracket, Hanger Left
50	Support, Fan Deck
51	Drain Hose, Flexible
52	Panel, Left
53	Panel, Right
54	Assy., Cover Connector
55	Assy., Intake Grille B (358mm)
56	Filter, B (348.0)
57	Foam, Discharge Center C

Model: R5CMY62CR

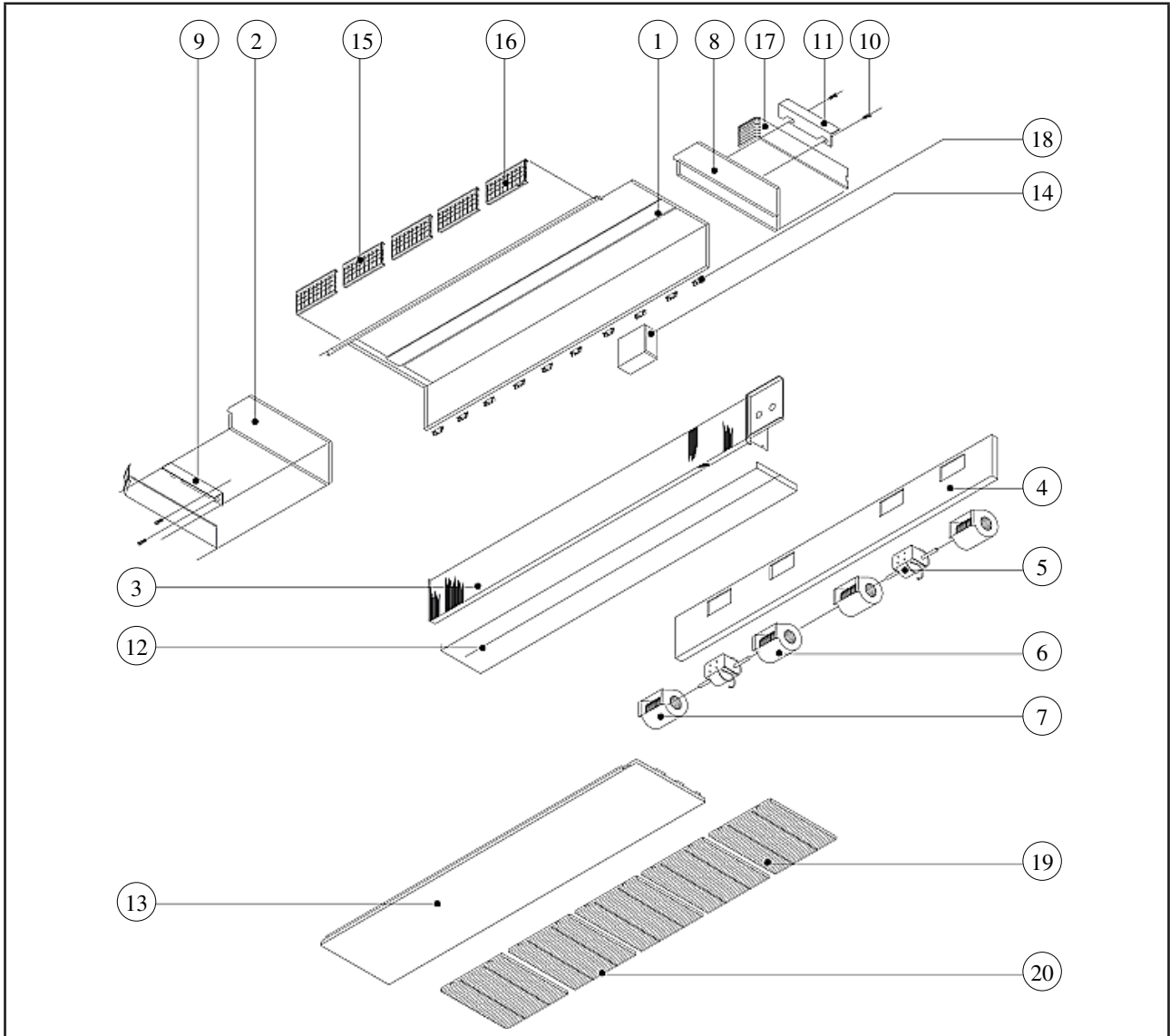

70024108767

No	Description
1	Assy. Top/Back Panel
2	Assy. Coil Holder - L
3	Assy. Coil
4	Assy. Fan Deck
5	Motor, MCC20C-504 4P 80W 1PH
6	Assy., Blower SYP160/200L
7	Assy., Blower SYP160/200R
8	Assy., Coil Holder - R
9	Hanger, Bracket L/H
10	Bolt, Dome Head Hex.

No	Description
11	Hanger, Bracket R/H
12	Assy., Drain Pan
13	Panel, Bottom
14	Assy., Control Box
15	Assy., Air Discharge
16	Assy., Air Discharge LED Logo
17	Assy., Side Panel
18	Hook
19	Air Intake Grille C/W Filter 390mm
20	Air Intake Grille C/W Filter 350mm

Outdoor Unit
Model: A5LCY28CR

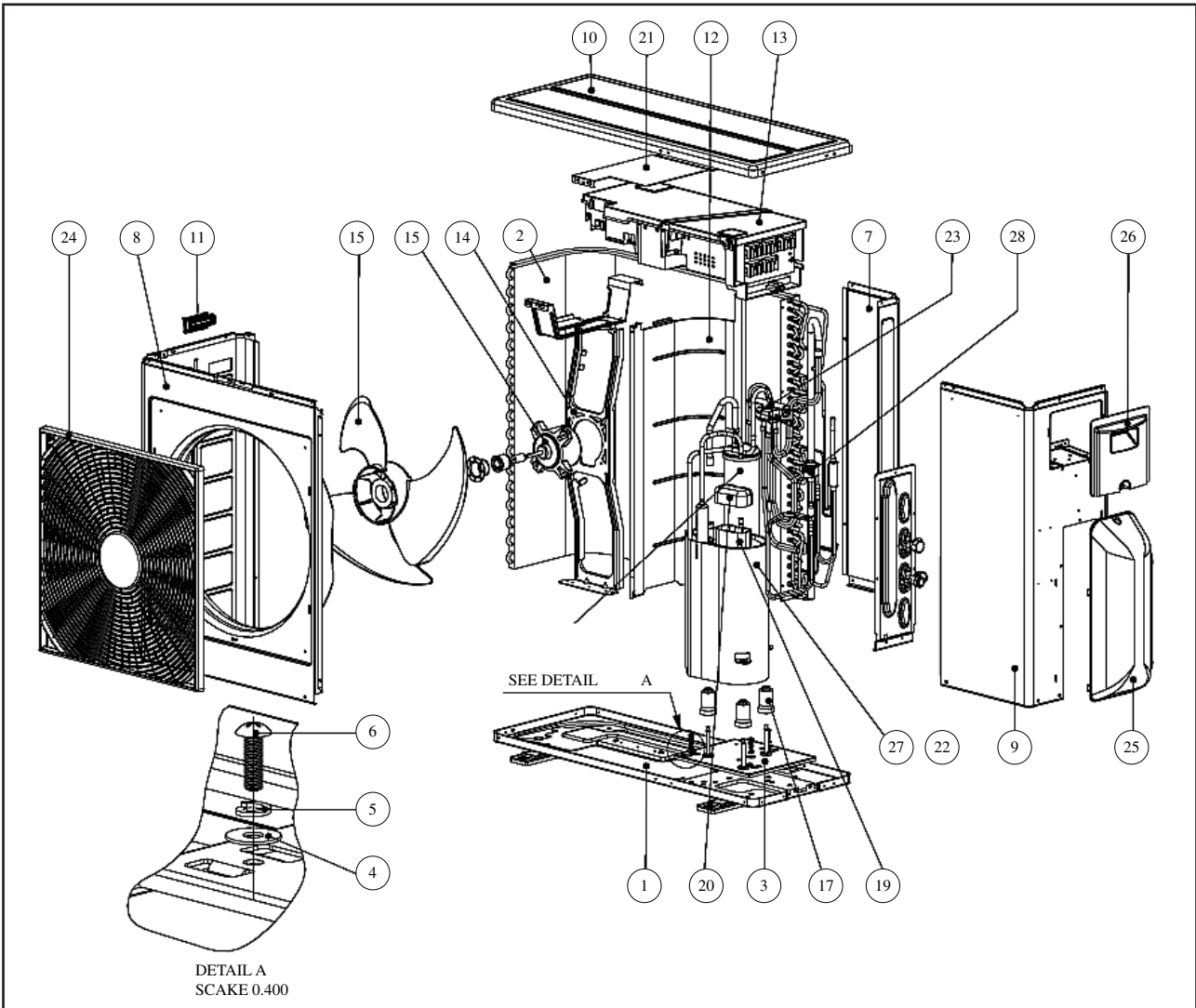

70014113428

No	Description
1	Assy., Panel Base
2	Assy., Condensor Coil
3	Assy., Comp Mounting Plate
4	Flat Washer
5	Washer, Spring
6	Screw, Truss Head Philip M6x20
7	Assy., Panel Right Back
8	Panel, Front/Left
9	Panel, Service
10	Assy., Panel Top
11	Plastic, Handle
12	Partition
13	Assy., Control Box (5SLY28CR)
14	Motor, Bracket

No	Description
15	Assy., Propeller Fan (2P160641-1)
16	Motor, A5MSY20/25/30BR-1 53W
17	Grommet, Compressor 2YC Daikin
18	Daikin Accumulator
19	Daikin Compressor 2YC45DXD
20	Terminal Cover, Daikin 2YC
21	Plate, Seal Board
22	Assy. Valve Plate with Flare Valve
23	Assy., 4 Way Valve
24	Plastic, Front Grille
25	Plastic, Valve Cover
26	Access, Cover
27	Compressor, Felt
28	Assy., EXV

Model: A5LCY40/50/60FR

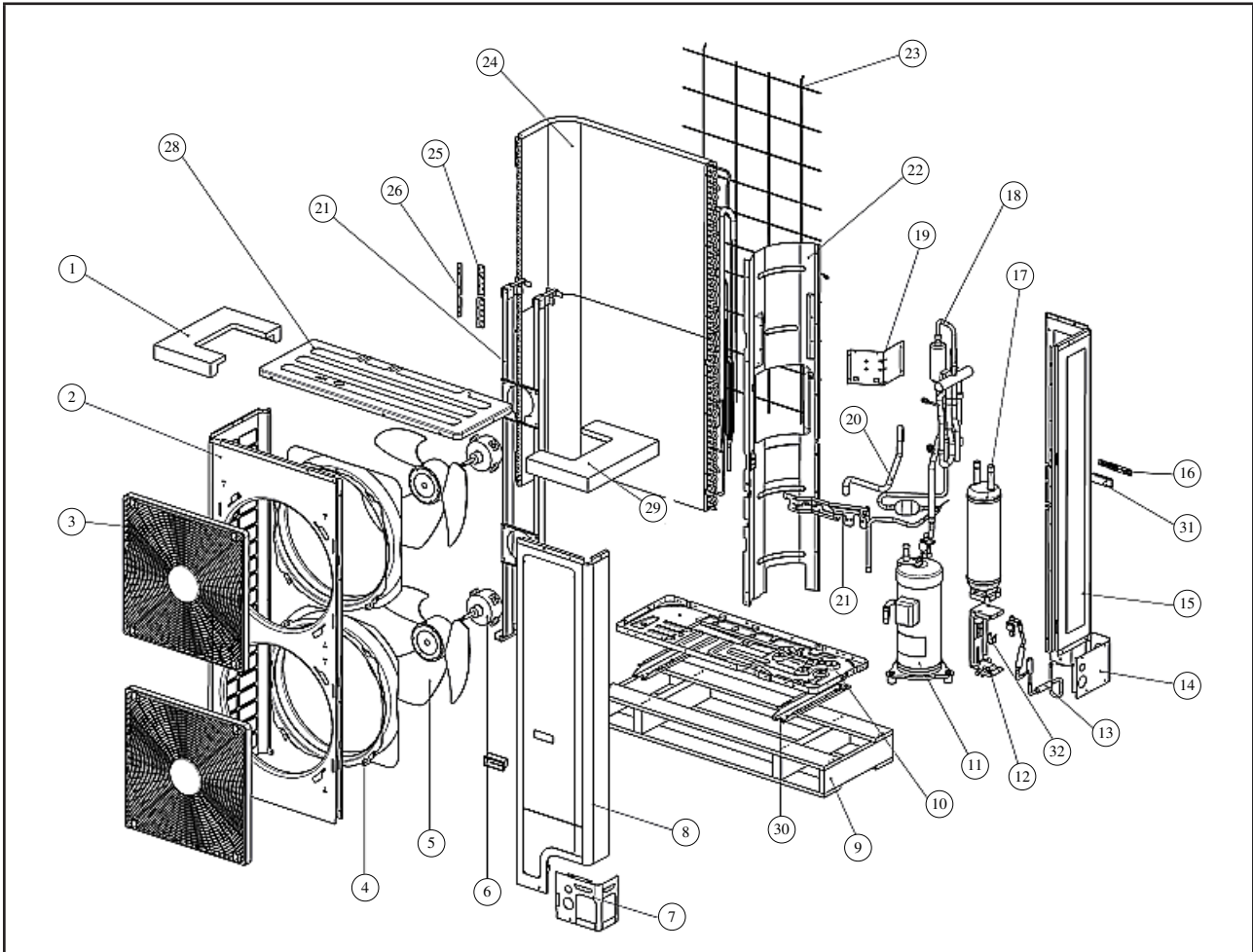

R70024116170

No	Description
1	Cushion, Top Left
2	Front, Plate
3	Front, Grille
4	Bellmouth
5	Propeller, Fan
6	Motor
7	Cover
8	Panel, Service
9	Wooden, Crates
10	Bottom, Plate
11	Compressor
12	Bracket, Accumulator
13	Assy., EXV
14	Cover, Rear
15	Right, Side Plate
16	Thermistor Holder

No	Description
17	Assy., Accumulator
18	Assy., 4WV
19	Reactor, Mounting Plate
20	Tube, Suction
21	Stop Valve, Mounting Plate
22	Partition Plate
23	Suction Grille
24	Assy., Outdoor Coil
25	Endplate, Hairpin
26	Endplate, Connector
27	Assy., Fan Motor Stand
28	Top, Plate
29	Cushion Top Right
30	Installation Leg
31	Plastic Handle Front
32	Clip, Muffler



While utmost care is taken in ensuring that all details in the publication are correct at time of going to press, we are constantly striving for improvement and therefore reserve the rights to alter model specifications and equipment without prior notice. Details of specifications and equipment are also subject to change to suit local conditions and requirements and not all models are available in every market.

